

Masterpiece of Embedded Voice Logger

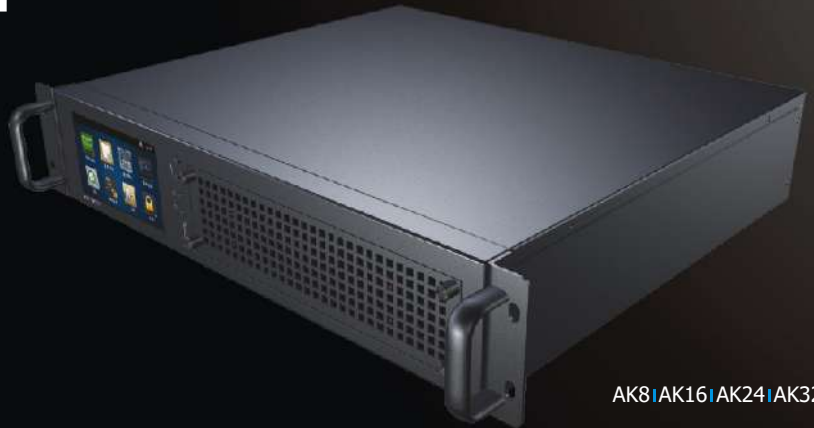

- Fully Standalone
- 8/16/24/32 Ports
- 5" HD Touch Screen
- Announcement & Answer

AK8|AK16|AK24|AK32



HD Touch Screen

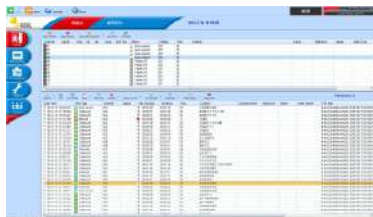

PC Client Software



Static Report



Central Management

Fully Standalone

World's first HD touch screen embedded voice logger. Record and playback on the device itself, no PC required.

Expandable Capacity

Each AK got 4 slots for line interface card. Which allow users to make it 8, 16, 24 or 32 port logger

Networking Feature

Connect to the internet or intranet via RJ45 jack. Users can access to the loggers by PC locally or remotely.

Call Detail Recording

AK doesn't just record the conversation. It also records the detail of each call, include call direction, time/date, duration, caller ID, trunk number and extension number. This is very helpful for users when they want to search a dedicated log

High Capacity Hard Disk Driver

Each AK logger comes with a removable 1TB HDD. The HDD is capable of storing 70,000 hours of conversation (for 16 channel model, 5 hours per day, 5 days per week, it can record for more than 3 years of calls)

Centralized Management

The Vault software is capable of manage all Artech AK, AQ and AJ series voice loggers centrally. The administrator can easily access to any device with this software. All the recording data can also be backup on one single server with this software.

e-mail Notification

Users can define the events which to be notified by email automatically, e.g. daily statistic report to the manager

Other Features

- 19" rack mount size
- In-built 5" HD touch screen
- In-built speaker
- 2 earphone jacks
- Low power consumption, low heat, fan-less
- Ethernet port
- Firmware remote upgrade
- Firmware upgrade by USB Flash
- Password protection
- Line status indication
- Line voltage sensor range adjustable
- Unanswered call counter
- Daily recording schedule programmable
- Multi account, multi authorization
- Call detail record can be export to Excel file format
- Send recording file via email
- Setting non-recording phone and extension number
- Setting non-recording period (e.g. ATM card password)
- HDD free space indication
- Caller ID pop up on PC
- System log
- Compatible with PBX's SMDR
- Import phone book from Outlook
- Backup automatically or manually
- Making remark on each record
- Multi language user interface
- Backup battery connector

Announcement

When the agent answers the call, AK will playback a pre-recorded speech to announce this call is been recorded.

Answering Machine Feature

Like a telephone answering device, the AK can answer the call, play greeting message and take the caller's message. This feature is activated by programmed schedule e.g. off duty hours

System Failure Alarm

AK's in-built alarm monitors the system non-stop. When any technical issue raised causes the system unable to record the calls, the alarm will generate audio alert till the system recovers

Multi Recording Interface

AK's recording interface includes PSTN trunk, analog extension of PBX, radio system, microphone and digital phone handset. All interface can be mixed on one single device

Live Call Monitoring

Administrator can listen to the live phone calls on the AK device or on the PC which runs BlackBox client software

Statistic Chart Report

The Blackbox client software generates various kinds of statistic chart report. It helps the supervisor to monitor the efficiency of the telephone system

Auto Gain Control

The sophisticated circuit design perfectly balance the volume of both local and remote sides of the call. Many loggers on the market got very soft volume from remote side

Diagram

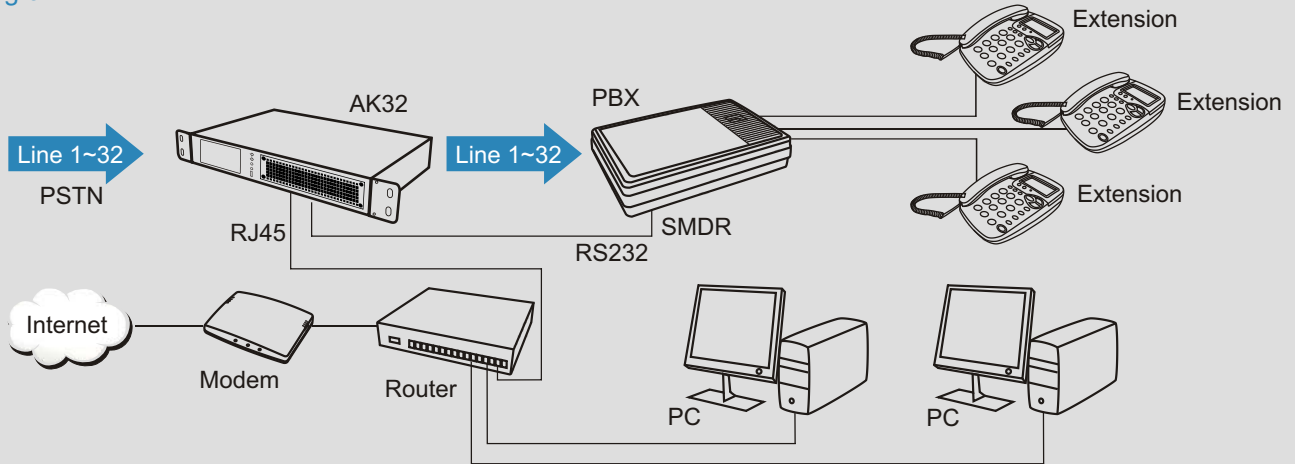

Model List

Model No.	AK8	AK16	AK24	AK32
Port	8	16	24	32

Dimension

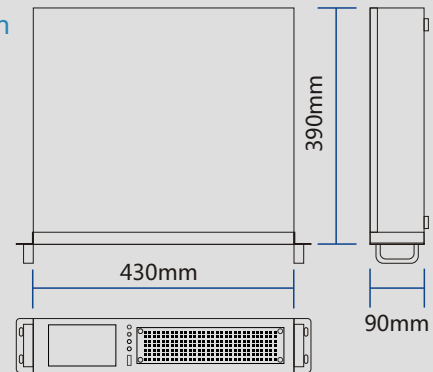

Specifications

Item	Specification
Port	8/16/24/32
HDD Capacity	1TB
Display	5" HD Touch Screen
Audio Format	ADPCM
Recording Time	70,000 hours/ 1TB
Trigger Type	Line voltage, Voice, Button
Off Hook V Range	3-80V
On Hook V Range	10-100V

Item	Specification
Caller ID	DTMF/FSK
CID Sensitivity	0dB to -32dB
Recoding Frequency	100 Hz to 3400 Hz
Input Impedance	AC:100K,DC:5.1M
S/N Ratio	>60dB
ACR	>70dB
Power Supply	DC19V
Working Current	1.5A

Item	Specification
Max. Current	3A
Power Consumption	30W
Backup Battery	24V Dry Battery
Working Temperature	0°C to 40°C
Working Humidity	10% to 90 %
Network Jack Type	RJ45
Line Jack Type	DB37 Cable

Leading Brand of Voice Logging Indutry



Artech Technology Design Co., Ltd.
www.artechvl.com
sales@artech.com.tw

