

# HN-PCM06B

## I Ceiling Loudspeaker

HN-PCM06B/ is a cost-competitive ceiling loudspeaker which has an excellent audio performance and a aesthetic appealing enclosure. Its low-profile, white color design blends easily most interiors in locations such as hotels, warehouses, schools, office buildings, stadiums and restaurants. This full range loudspeaker features a high sound pressure level and a wide frequency response range. It has a built-in 6W integrative-cone speaker and a 100V matching transformer mounted back dome, Supplied with a metal back dome, the components inside are well protected in case of emergency.



## ABOUT THE PRODUCT

HN-PCM06B is fully metal speaker. The powder coated grille is well fixed in Basket.

## CERTIFICATIONS AND APPROVAL

CE Complied

## FEATURES AND BENEFIT



**FLUSH-MOUNTING SYSTEM FOR FAST AND EASY INSTALLATION**



**WIDE FREQUENCY RESPONSE FOR EXCELLENT SPEECH AND MUSIC REPRODUCTION**



**EXCELLENT CRASH AND RUST RESISTANT DESIGN**



**FULLY METAL SPEAKER WITH METAL BASKET AND GRILLE**

## INSTALLATION DETAILS/DIMENSIONS

HN-PCM06B has two spring clamps which can be used to easily fix the speaker into the false ceiling. It has three power taps (6/3/1.5W) with the built in 100V transformer. The round metal grille is well fitted in the front.

# DIMENSIONS

## THREE-VIEW DIAGRAM

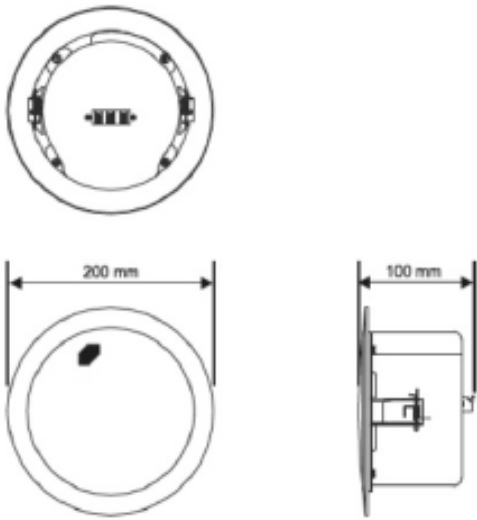

## Circuit Diagram:

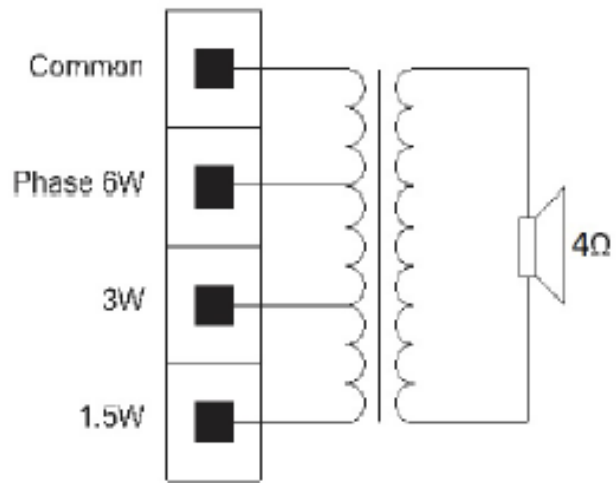

# TECHNICAL SPECIFICATIONS

### SYSTEM PERFORMANCE

Frequency Range (-10 dB)	110 Hz - 20 kHz
Nominal Dispersion	180° Conical
Rated Impedance	1.7 KΩ at 6 W
Long-Term Power Handling	6 W (9 W peak)
Sensitivity (SPL / 1 W @ 1 m)	92 dB SPL
Maximum SPL @ 1 m	100 dB SPL (dB SPL peak)
Rated Input Voltage	100V/70V
Transformer Taps (100 V)	6W / 3 W/ 1.5 W

### TRANSDUCERS

Driver Compliment	6" (150 mm) full-range driver
-------------------	-------------------------------

### PHYSIC

Enclosure	Powder-coated metal basket
Grille	Powder-coated metal grille
Environmental	Indoor use only
Connectors	Push type terminal
Suspension / Mounting	Two integrated quick-install mounting clamps.
Dimensions	Outer diameter: (200 mm) Height: (100 mm) Ceiling hole diameter: (165 mm)
Ceiling Thickness (Maximum)	(25 mm)
Net Weight	(1.0 kg)
Shipping Weight	1.25kg (Gross weight with packing)
Colour	White( RAL 9003)

### For more information,

www.honeywellbuildings.in  
 Call: 000-8000-502167  
 Email: HBT-IndiaBuildings@Honeywell.com

### Honeywell HBT India Buildings

Unitech Trade Center, 5th Floor, Sector-43,  
 Block C, Sushant Lok Phase - I,  
 Gurgaon - 122 002.

HN-PCM06B | 01 | 09/21  
 © 2021 Honeywell International Inc.

**THE  
 FUTURE  
 IS  
 WHAT  
 WE  
 MAKE IT**

**Honeywell**