

HN-PWP12A

I Cabinet Loudspeaker

KEY FEATURES

- 12W speaker with powerful and intelligible audio performance
- Stylish design
- Simple power setting
- High impact and fire resistant ABS material
Easy installation and cost effective

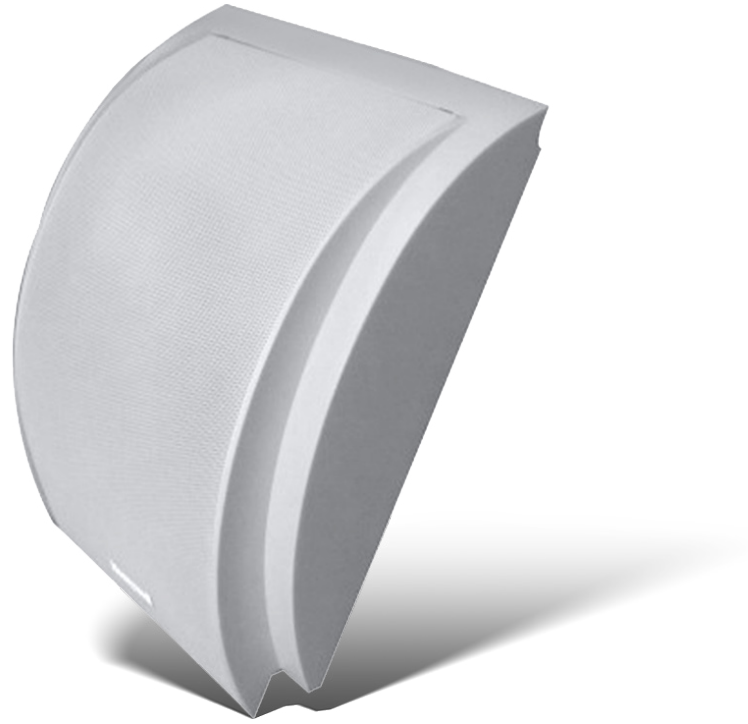

HN-PWP12A/ is a 12W cabinet loudspeaker typically used for general public address applications such as shopping malls, supermarkets, educational institutes, office buildings, hotels, and restaurants. The loudspeaker offers high sound pressure level and wide frequency range, which result in excellent audio and music reproduction. Equipped with high linearity anti-fatigue rubber, the bass audio performance is free from distortion due to a prolonged low-frequency operation.

CE Complied

With 12W, 6W, 3W adjustable switches for power handling unit available, the speaker is capable to deliver clear and lucid audio performance on different applications. Push type terminal on the back box allows easy cable connection. The stylish design made of high impact ABS material is finished in unobtrusive white color. The product has an extraordinary bass response effect.

TECHNICAL SPECIFICATIONS

Max power	18W
Rated power	12W
Power taps @ 100V	12W / 6W / 3W
SPL at 1W (1k Hz, 1m)	92 dB
Frequency response (- 10 dB)	110 Hz - 14k Hz
Dispersion angle (1k Hz / -6 dB)	170°
Rated input voltage	100 V
Rated impedance	833 Ω / 1667 Ω / 3333 Ω
Connector	Push terminal
Dimensions (W × H × D)	240 × 345 × 100 mm
Diameter of speaker	6.3" (160 MM)
Weight	1.450 kg
Color	White
Weight of magnet	150 g.

FREQUENCY RESPONSE

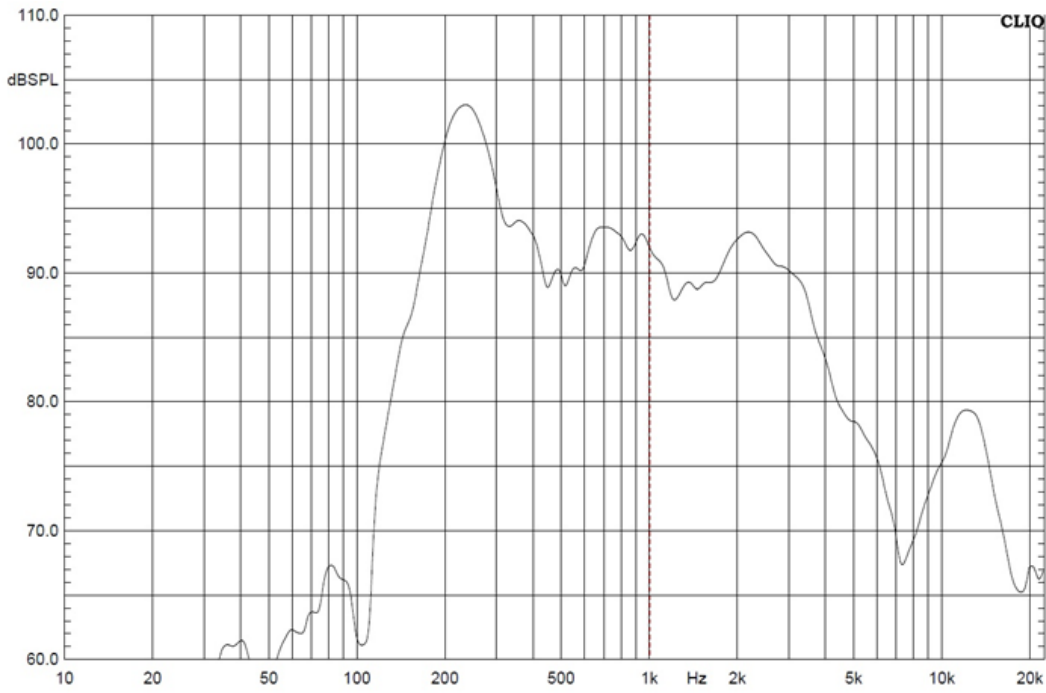

CIRCUIT DIAGRAM

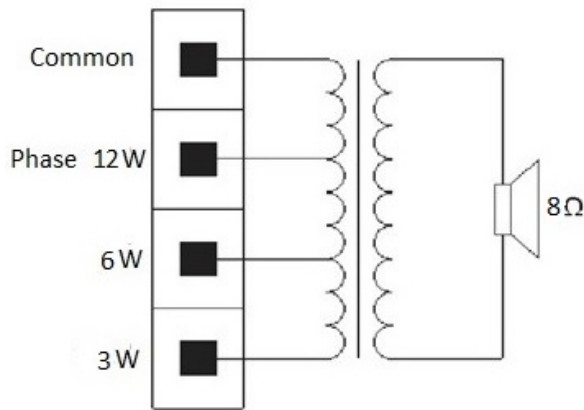

THREE-VIEW DIAGRAM

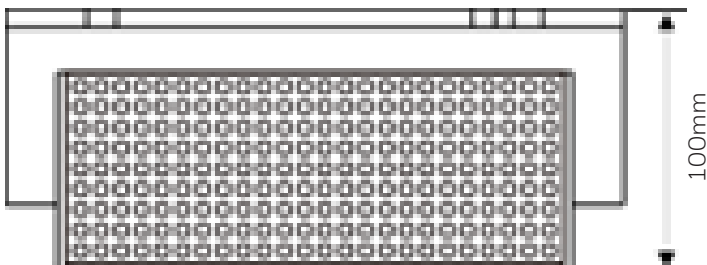
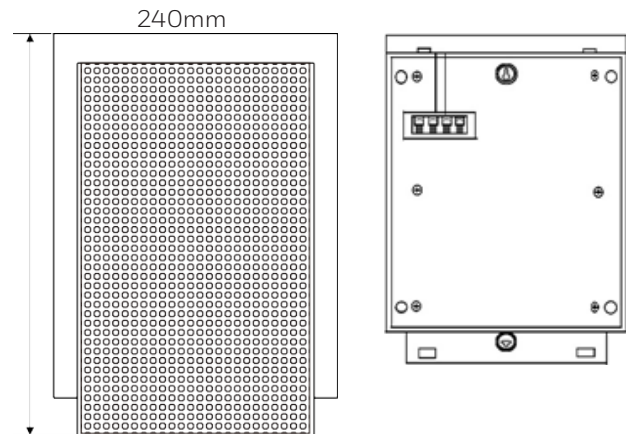

For more information,

www.honeywellbuildings.in

Call: 000-8000-502167

Email: HBT-IndiaBuildings@Honeywell.com

Honeywell HBT India Buildings

Unitech Trade Center, 5th Floor, Sector-43,

Block C, Sushant Lok Phase - I,

Gurgaon - 122 002.

www.honeywell.com

HN-PWP12A

Honeywell