

L-PWP80B

ABS

FULL RANGE

CABINET

- Water-proof cone
- Powerful and intelligible audio performance
- Suitable in humid condition
- Stylish design
- Simple power setting
- High strength and fire resistant ABS enclosure
- Easy installation and cost effective
- CE and RoHS complied



PRODUCT DESCRIPTION

L-PWP80B is a versatile, 80W cabinet loudspeaker intended for use in general indoor applications. The loudspeaker is ideal for use in theme bars, music restaurants, groceries, video shops, meeting rooms, office buildings, exhibition halls, gyms, and presentation rooms. Equipped with high linearity anti-fatigue rubber, the bass audio performance is free from distortion due to prolonged low-frequency operation. Treble circuit unit adopts dome Cortina design,

extending the treble range of frequency response and increasing the high quality acoustic performance. The traditional screw type terminal makes it easier for connection. A 5-step volume can be controlled by knob console on the back box. The adjustable installation brackets flexibly position the loudspeakers that meet the needs of different indoors sound field characteristics. The loudspeaker is CE and RoHS complied.

Technical Specification

Max power	100 W
Rated power	80 W
Power taps @ 100V	80 W / 40 W / 20 W
Power taps @ 70V	40 W / 20 W / 10 W
SPL at 80W / 1W (1kHz, 1m)	113 dB / 96 dB
Frequency range (-10dB)	60 Hz - 20kHz
Dispersion angle (1KHz / -6dB)	115 °
Rated impedance	125 Ω / 250 Ω / 500 Ω

Rated input voltage	100V / 70V / 8 Ω
Connector	Binding post terminals
Dimensions (W×H×D)	275 × 455 × 261 mm
Diameter of speaker	8" woofer, 1" tweeter
Weight	7.5 kg
Color	Charcoal (RAL 7021)

Frequency Response

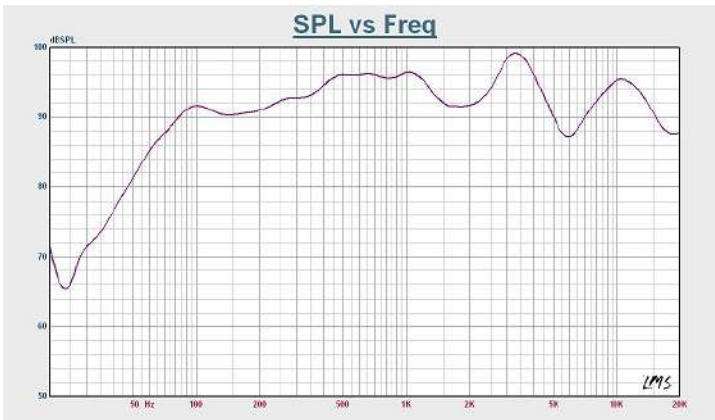

Circuit Diagram

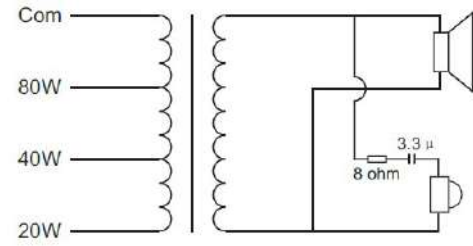

Polar Diagram

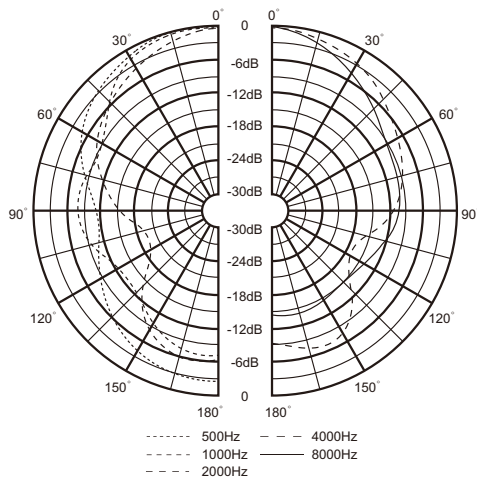

Three-View Diagram

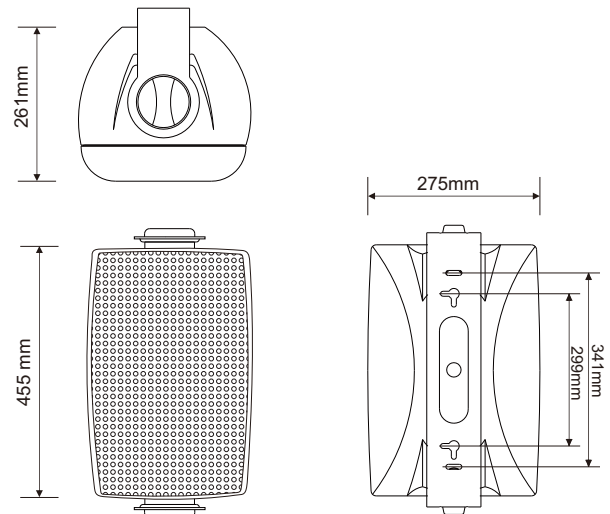

For more information,
<https://honeywellbuildings.in>
 Call: 1-800-103-0339
 Email: HBT-Indiabuildings@honeywell.com

Honeywell HBT India Buildings
 Unitech Trade Center, 5th Floor, Sector-43,
 Block C, Sushant Lok Phase - I,
 Gurgaon - 122 002

www.honeywell.com

© 2020 Honeywell International Inc.

L-PWP80B
ABS
FULL RANGE
CABINET

Honeywell