

HN-PHP15A

I Horn Loudspeaker

HN-PHP15A/ is a 15W full range horn loudspeaker for high Power handling and reliability. Taps on the primary winding allow different power setting. Housing is made of sturdy ABS fire resistance material with strength and low weight. With its the aesthetical and style design, it can be installed in various applications such as train station, harbors, plaza, police station government administration, tourist destinations, educational institute, transport hubs, and office building. The horn is attached with strong and adjustable mounting brackets which help to accurately direct the sound beam. The loudspeaker is CE complied.



ABOUT THE PRODUCT

The speaker enclosure is fully made with ABS with glossy finish.

CERTIFICATIONS AND APPROVAL

CE Complied/IP 66

FEATURES AND BENEFIT



**HIGH IMPACT FIRE
RESISTANCE ABS MATERIAL**



**LOWER
MAINTENANCE COST**



**RUST & CHEMICAL
RESISTANT**



**WATER AND DUST
PROTECTED IP 66**

INSTALLATION DETAILS/DIMENSIONS

HN-PHP15A/ is a horn loudspeaker which can be Used to easily adjustable mounting brackets in any Surface to accurately direct the sound beam. It has Three power tapping (15/7.5/3.75W) with built in 100V transformer.

DIMENSIONS

THREE-VIEW DIAGRAM

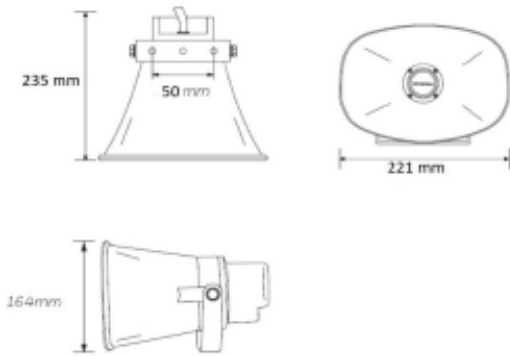

Circuit Diagram:

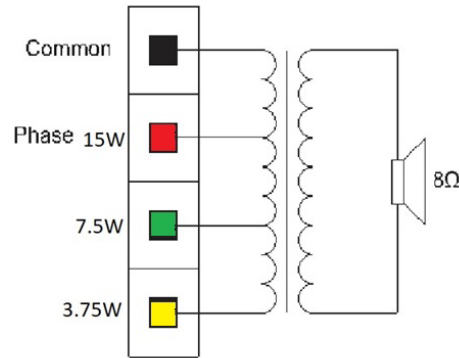

TECHNICAL SPECIFICATIONS

SYSTEM PERFORMANCE

| | |
|-----------------------------|---------------------|
| Frequency Range (-10dB) | 350Hz – 8 KHz |
| Nominal Dispersion | 140° (H) X 50° (V) |
| Rated Impedance | 667 Ω at 15 W |
| Long-Term Power Handling | 15 W (22W peak) |
| Sensitivity (SPL / 1 W @1m) | 104 dB SPL |
| Maximum SPL @1m | 116 dB SPL |
| Rated Input Voltage | 100 V/ 70V |
| Transformer Taps (100V) | 15 W / 7.5W/ 3.75 W |

PHYSIC

| | |
|-----------------------|---|
| Enclosure | ABS |
| Environmental | Outdoor uses, IP 66 |
| Operating Temperature | -25° C to 55° C |
| Storage Temperature | -40° C to 70° C |
| Relative Humidity | <95% |
| Connectors | 4 CORE Flexible wire having 4 connection of Com, 15W, 7.5W, & 3.75W |
| Suspension/Mounting | U Shape mounting clamp is fixed in speaker and can be mount easily on any wall with 3 holes in clamp. |
| Dimensions | Length- 221mm Width- 164mm Height- 235 mm |
| Colour | White(RAL 9003) |
| Net Weight | (1.38kg) |
| Shipping Weight | (1.68Kg) |

For more information,

www.honeywellbuildings.in

Call: 000-8000-502167

Email: HBT-IndiaBuildings@Honeywell.com

Honeywell HBT India Buildings

Unitech Trade Center, 5th Floor, Sector-43,

Block C, Sushant Lok Phase - I,

Gurgaon - 122 002.

HN-PHP15A | 01 | 09/21
© 2021 Honeywell International Inc.

**THE
FUTURE
IS
WHAT
WE
MAKE IT**

Honeywell