



DAG3000-312S FXS Gateway

User Manual V1.0



Shenzhen Dinstar Co., Ltd.

Address: Floor 18, Building 7A, Vanke Cloud City Phase 1, Xingke 1st Street, Xili Sub-district, Nanshan District, Shenzhen.

Postal Code: 518052

Telephone: +86 755 61919966

Fax: +86 755 2645 6659

Email: sales@dinstar.com

Website: www.dinstar.com

Preface

Welcome

Thanks for choosing the **Dinstar's Product**! We hope you will make full use of this rich-feature FXS Gateway. Contact us if you need any technical support: +86-755-61919966.

About This Manual

This manual provides information about the introduction of the analog telephone adapter, and about how to install, configure, or use it. Please read this document carefully before installing the gateway.

Note: DAG3000 in this user manual will be called a device or gateway!

Intended Audience

This manual is aimed primarily at the following people:

- Users
- Engineers who install, configure, and maintain the gateway.

Document Information

Document Name	DAG3000-312S FXS Gateway User Manual V1.0
Document Version	1.0
Firmware Version	2.83.11.27
Revised by	Ellie Zhang
Date	11/01/2023

Revision Record

Version	Date	Revision	Reason	Author
V1.0	11/01/2023	Refine the content of the first draft	Required for new product launches	Ellie Zhang

Contents

1 Product Introduction.....	1
1.1 Overview	1
1.2 Application Scenario.....	1
1.3 Outlooks of Products.....	2
1.3.1 Outlooks of Device.....	2
1.3.2 Ports and Connectors.....	3
1.4 Features & Functions	5
1.4.1 Key Features	5
1.4.2 Physical Interfaces.....	5
1.4.3 Voice Capabilities & Fax.....	5
1.4.4 FXS	6
1.4.5 VoIP.....	6
1.4.6 Call Features	7
1.4.7 Security.....	8
1.4.8 Physical Features.....	8
1.4.9 Maintenance.....	8
2 Quick Installation	10
2.3 Installation Attentions.....	10
2.2 Installation Steps.....	10
3 Basic Operation	12
3.1 Methods to Number Dialing	12
3.2 Call Holding	12
3.3 Call Waiting.....	12
3.4 Call Transfer	13

3.4.1 Blind Transfer.....	13
3.4.2 Attended Transfer	13
3.5 Function of Flash-hook.....	14
3.6 Description of Feature Code.....	14
3.7 Send or Receive Fax	16
3.7.1 Fax Mode Supported.....	16
3.7.2 Explanation of T.38 and Pass-through.....	16
3.8 Function of RST Button.....	17
3.9 Query IP Address and Restore Default Setting	17
4 Configurations on Web Interface	19
4.1 Access WEB Interface	19
4.1.1 Preparation for Login	19
4.1.2 Log in WEB.....	21
4.2 Navigation Tree	22
4.3 Status & Statistics	23
4.3.1 System Information.....	24
4.3.2 DTU Status.....	28
4.3.3 Port Status.....	29
4.3.4 Current Call	31
4.3.5 RTP Session.....	31
4.3.6 CDR.....	31
4.3.7 Record Statistics	33
4.4 Quick Setup Wizard	33
4.5 Network.....	33
4.5.1 Local Network	33
4.5.2 VLAN (Virtual Local Area Network).....	35

4.5.3 DHCP Option.....	37
4.5.4 QoS	38
4.5.5 ARP	39
4.6 SIP Server.....	40
4.7 IP Profile.....	43
4.8 Tel Profile	43
4.9 Port	43
4.10 Advanced.....	46
4.10.1 Line Parameter	46
4.10.2 FXS Parameter	50
4.10.3 Media Parameter	53
4.10.4 Service Parameter	55
4.10.5 SIP Compatibility.....	59
4.10.6 NAT Parameter	65
4.10.7 Speed Dial.....	66
4.10.8 Feature Code.....	67
4.10.9 System Parameter	69
4.11 Call & Routing	72
4.11.1 Wildcard Group.....	72
4.11.2 Port Group	72
4.11.3 IP Trunk	76
4.11.4 Routing Parameter.....	77
4.11.5 IP ->Tel Routing.....	77
4.11.6 Tel->IP/Tel Routing.....	79
4.12 Manipulation.....	80
4.12.1 IP->Tel Called.....	80
4.12.2 Tel->IP/Tel Caller	82

4.12.3 Tel->IP/Tel Called	85
4.13 Management.....	87
4.13.1 TR069.....	87
4.13.2 SNMP.....	89
4.13.3 Syslog	92
4.13.4 Provision.....	93
4.13.5 Cloud server.....	95
4.13.6 User Manage.....	95
4.13.7 Remote Server.....	96
4.13.8 Record Parameter.....	97
4.13.9 Radius Parameter	98
4.13.10 Action URL.....	98
4.13.11 SIP PNP.....	99
4.13.12 NMS Configuration	100
4.14 Security	101
4.14.1 WEB ACL.....	101
4.14.2 Telnet ACL	102
4.14.3 Passwords.....	103
4.14.4 Encrypt.....	103
4.15 Tools.....	104
4.15.1 Firmware Upload	104
4.15.2 Data Backup.....	105
4.15.3 Data Restore.....	105
4.15.4 Outward Test.....	106
4.15.5 Ping Test	106
4.15.6 Tracert Test.....	107
4.15.7 Network Capture.....	108

4.15.8 Factory Reset.....	111
4.15.9 Device Restart.....	111
5 Glossary.....	113

1 Product Introduction

1.1 Overview

The DAG3000 Series FXS analog gateway is a multi-functional voice gateway that provides seamless connectivity with analog phones, fax machines, or analog PBXs to VoIP gateway. The overall frame of DAG3000 is compact and structured, supporting RJ21 interface standards and up to 312 FXS voice interfaces via user boards plugging at a size of 3U. In addition, DAG3000 provides high-performance hardware solutions with good voice/fax processing capability. It can provide efficient and high-quality IP voice services for service providers, enterprises, community residents, and corporate telephone systems.

DAG3000 supports standard SIP and RTP protocols and is compatible with multiple well-known platforms, for example, compatible with BroadSoft. It also works as extension with various IPPBX products based on Asterisk and FreeSWITCH and is also perfectly compatible with IMS/NGN softswitch platforms and call center systems. In addition, customers can build an enterprise branch communication network by using the DAG3000 to achieve interoperability between branches, which can provide an efficient, stable, and cost-effective voice communication solution for large enterprises.

1.2 Application Scenario

The application scenario of the device is shown as follows:

Figure-Application Scenario of the device

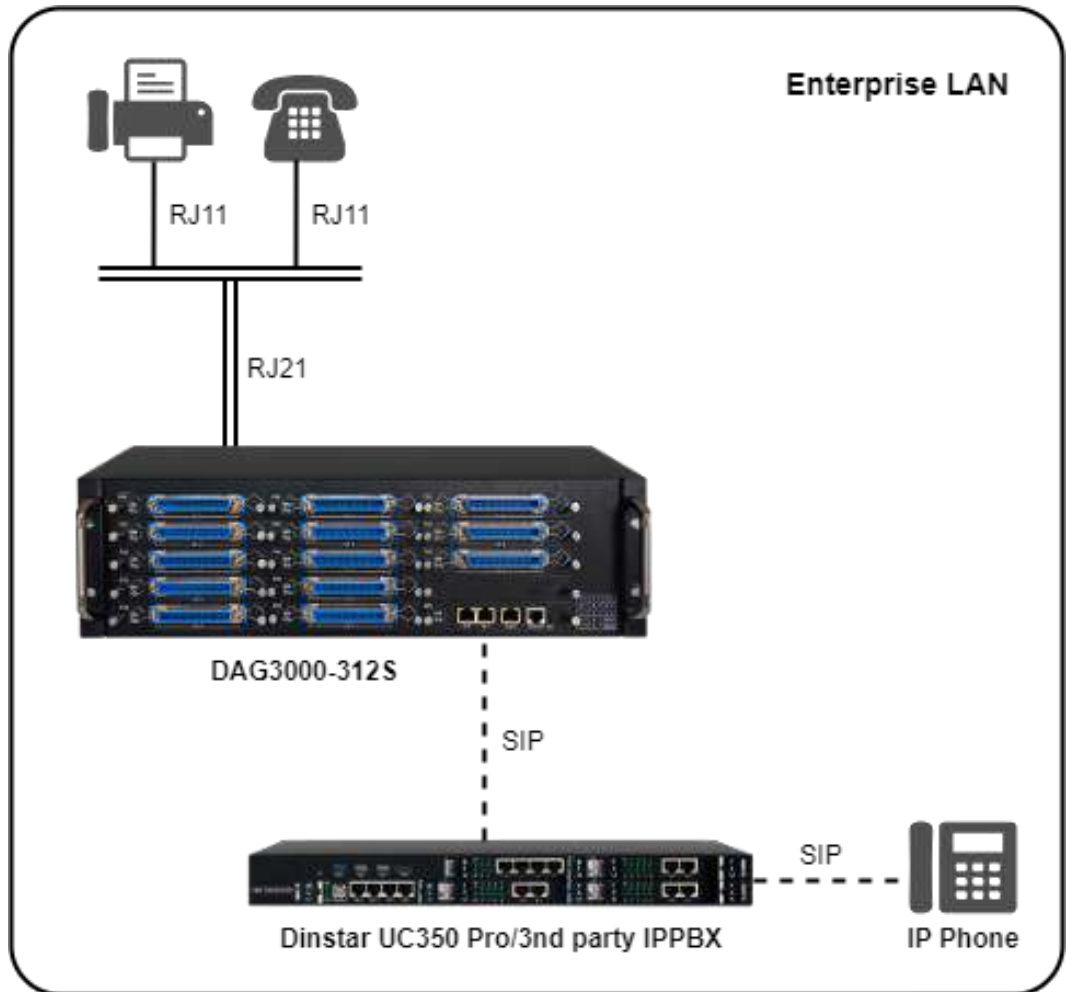

1.3 Outlooks of Products

1.3.1 Outlooks of Device

Front View:



Back View:



1.3.2 Ports and Connectors

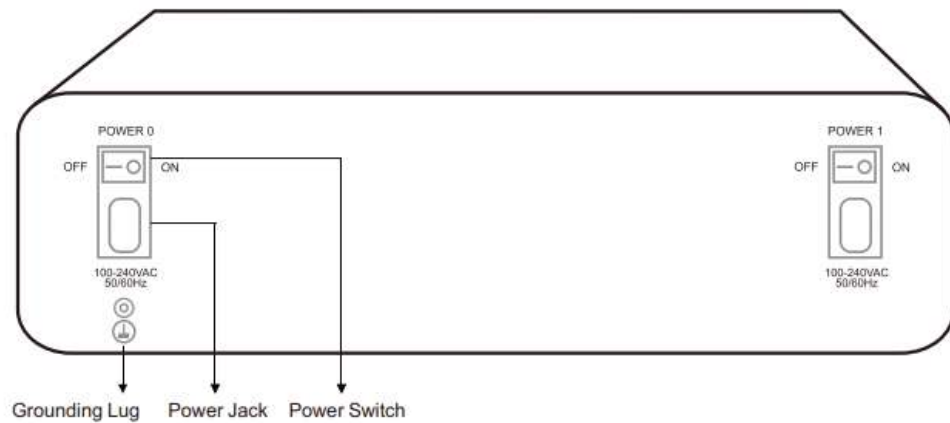
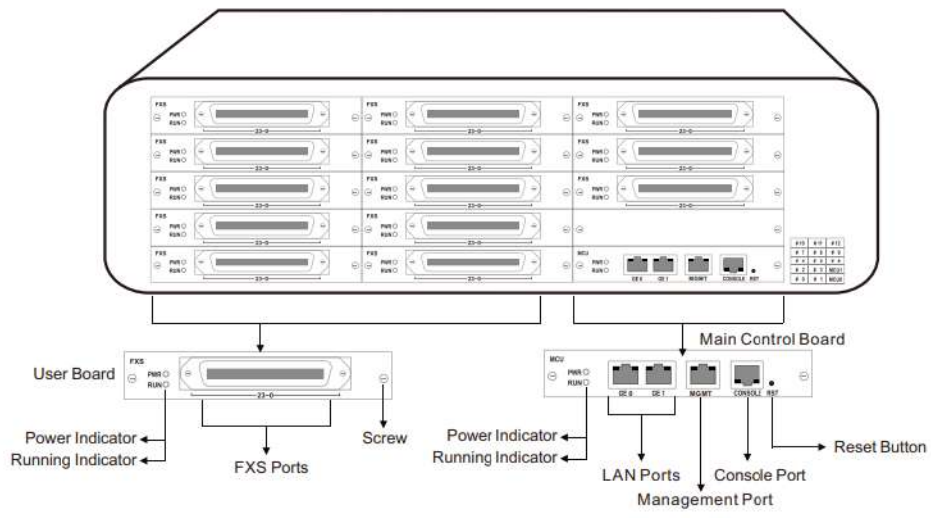

The description of indicators:

Indicator	Definition	Status	Description
PWR	Power Indicator	On	The gateway is powered on
		Off	The gateway is powered off or there is no power supply
RUN	Running Indicator	Slow Flashing	The gateway is running properly (Slow Flashing means the running indicator flashing for 2 seconds)
		Fast Flashing	SIP account is registered successfully (Fast Flashing means the running indicator flashing for 0.5 seconds)
		Off	The gateway is running improperly
MGMT	Network Link Indicator	Green Flashing	The gateway is properly connected to the network
		Off	The gateway is not connected to the network or the network connection is an improper way.
	Network Speed Indicator	On	Work at 100Mbps
		Off	Work at 10Mbps
GE0/GE1	Network Link Indicator	Green Flashing	The gateway is properly connected to the network
		Off	The gateway is not connected to the network or the network connection is an improper way.
	Network Speed	On	Work at 1000Mbps

	Indicator	Off	Work at 10Mbps
--	-----------	-----	----------------

1.4 Features & Functions

1.4.1 Key Features

- High-density gateway, 24 to 312 FXS ports in 3U size via user boards plugging
- Support IPv4 and IPv6
- 5 km Line Length(MAX)
- Support SNMP and TR069
- Multiple codecs: G.711A/U,G.723.1,G.729A/B and iLBC
- Support Asterisk and FreeSWITCH platforms, and compatible with BroadSoft
- Fully compatible with leading IMS/NGN, SIP-based IP telephony system

1.4.2 Physical Interfaces

- Hardware 1*MCU Board 13*User Boards
- FXS Boards
 - RJ21: One user board supports 24 FXS ports, up to 13 user boards
- MCU Board
 - Network Interfaces:
 - 2* 10/1000 Base-T, 1* 10/100 Base-T
 - Console: 1* RS232, 115200bps

1.4.3 Voice Capabilities & Fax

- Recording
- T.38/Pass-through
- Modem/POS

-
- Silence Suppression
 - Bandwidth Optimization
 - Comfort Noise Generation (CNG)
 - Voice Activity Detection (VAD)
 - Packet Loss Concealment
 - Adaptive (Dynamic) Jitter Buffer
 - Programmable Gain Control
 - G.711A/U law, G.723.1, G.729A/B, G.726, iLBC, AMR, AMR-GSM
 - DTMF mode: Signal/RFC2833/INBAND
 - Echo Cancellation (G.168), with up to 128ms

1.4.4 FXS

- Connector: RJ21
- Max Line Length: 5 km
- Reversed Polarity
- Pulse: 10 and 20 PPS
- Dial Mode: DTMF and Pulse
- Programmable Call Progress Tone
- Caller ID: DTMF/FSK CLI Presentation

1.4.5 VoIP

Protocol:

- SIP v2.0 (UDP/TCP), RFC3261
- SDP(RFC2327), RTP(RFC2833), RFC3262, RFC3263, RFC3264, RFC3265, RFC3515, RFC2976, RFC3311
- RTP/RTCP, RFC2198, RFC1889
- IPv4 and IPv6
- Outbound Proxy
- Master/Slave Server

-
- RFC2806 TEL URI
 - RFC3581 NAT, rport
 - VLAN 802.1P/802.1Q
 - RFC4028 Session Timer
 - DNS SRV/A Query/NATPR Query
 - NAT: STUN, Static/Dynamic NAT

1.4.6 Call Features

- Digit map
- IMPU
- Action URL
- Voicemail
- Custom IVR
- Call Waiting, Call Holding
- Do-not-disturb
- Blind/Attended Transfer
- Call Forward on Busy
- Call Forward on No Reply
- Ringing Group, Hotline
- 3-way Conference
- Early Media/Early Answer
- Abbreviated Dialing
- Access and Peer Mode
- SIP PnP Auto Provisioning
- PBX IVR
- Unconditional Call Forward
- SIP registration to different servers
- Flexible Call Routing Policy
- Caller/Called Number Manipulation

1.4.7 Security

- QoS, TLS, SRTP
- Web ACL/SSH ACL
- RADIUS Authentication
- Certification Management
- Service Network Port: Isolated/BOND/Bridge Mode
- Signaling/Voice Encryption

1.4.8 Physical Features

- Power Supply: 100-240VAC, 50/60Hz
- Dual power supplies
- Operating Temperature: 0°C ~ 45°C
- Storage Temperature: -20°C ~80°C
- Humidity: 10%-90% Non-Condensing
- Dimensions(W/D/H): 440*360*132mm(3U)
- Consumption (Idle/With full channel used): 150W/400W
- Unit Weight: 12 kg
- Compliance: CE and FCC

1.4.9 Maintenance

- CDR
- Ping/Tracert Test
- Network Capture
- Outward Test (GR909)
- SNMP, TR069, Provision
- NTP/Daylight Saving Time
- IVR local Maintenance
- RADIUS Authentication Management

-
- Cloud-based Management (NMS)
 - Syslog: Debug, Info, Error, Warning, Notice
 - Configuration Backup/Restore
 - Firmware Upgrade via HTTP/HTTPS/TFTP/FTP/HTTP

2 Quick Installation

2.3 Installation Attentions

To avoid unexpected accidents or device damage, please read the following instructions before installing the device: The device is equipped with RJ21 ports;

- Anti-jamming: to reduce the interference with telephone calls, it' s highly recommended that telephone lines connected to the gateway should be placed away from power cables;
- Power supply: the power adapter of the device accepts 100-240V AC power supply. Please ensure a safe and stable power supply.
- Network bandwidth: please ensure there is enough network bandwidth to guarantee stabilized running of the gateway;
- Ventilation: to avoid overheating, please do not pile up the gateway with other devices, and make sure the gateway has good ventilation around;
- Temperature and humidity: to avoid any accident that might cause malfunction, it' s advised to install the gateway in an equipment room where temperature and humidity are appropriate;
- Mechanical load: please make sure the gateway is placed steadily to avoid damage. It is highly advised to horizontally place the gateway on a flat surface or a cabinet.

2.2 Installation Steps

- Connection Diagram for DAG3000-312S
- Connect gateway with the network via a switch, and connect FXS ports with analog phones

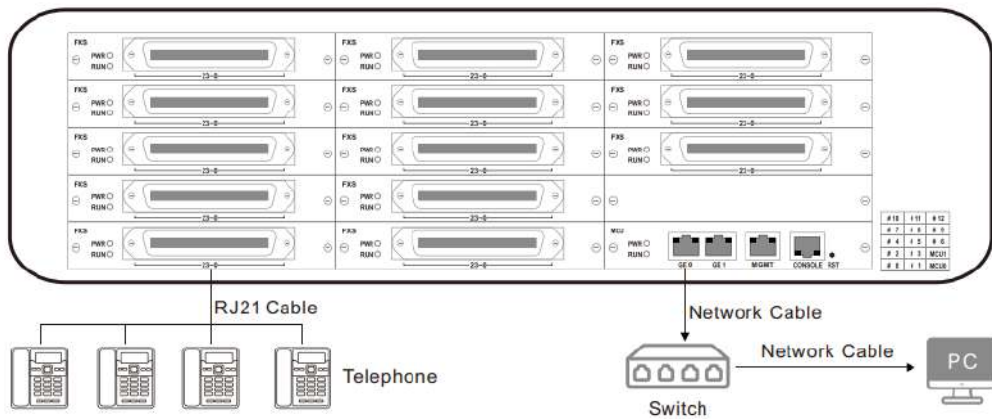

- Connect gateway with power supply and grounding lug

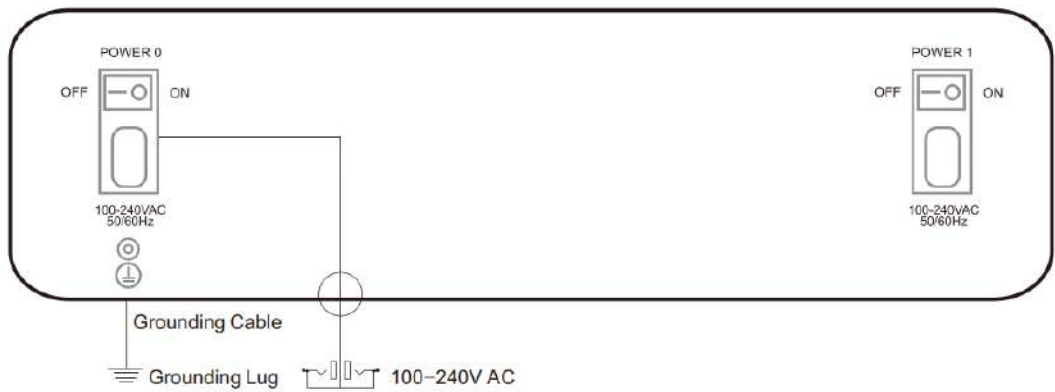

3 Basic Operation

3.1 Methods to Number Dialing

There are two methods to dial a telephone number or extension number:

- Dial the called number and wait for 4 seconds for dialing timeout, or dial the called number directly (the system will judge whether the dialing is completed according to Digitmap and Regular Expression dial plans).
- Dial the called number and press #.

3.2 Call Holding

If a calling party places a call to a called party that is otherwise engaged, and the called party has the call holding feature enabled, the called party can switch to the new incoming call while keeping the current call holding on by dialing *# or pressing the flash button/flash hook.

When the called party dials *# once again or presses the flash button/ flash hook once again, he or she will switch back to the first call.

3.3 Call Waiting

If a calling party places a call to a called party that is otherwise engaged, and the called party has the call waiting feature enabled, the calling party will hear an IVR voice 'Please hold on, the subscriber you dialed is busy' and the called party will hear three beeps if waiting tone is enabled.

By pressing the flash button or the flash hook, the called party can switch between the new incoming call and the current call.

3.4 Call Transfer

3.4.1 Blind Transfer

Blind transfer is a call transfer in which the transferring party connects the call to a third party without notifying the third party.

Example: A gives a call to B and B wants to blindly transfer the call to C. Operation instructions are as follows:

- 3.2.1.1.1.1.1 A dials the extension number of B;
- 3.2.1.1.1.1.2 The extension of B rings, and B picks up the phone. Then A and B go into conversation;
- 3.2.1.1.1.1.3 B presses the flash button (or flash hook), and dials *87* after hearing a dialing tone to trigger a blind transfer. Then B dials the extension number of C (end up with #).
- 3.2.1.1.1.1.4 The extension of C rings, B hangs up the phone and C picks up the phone. Then C and A go into conversation.

Note:

- On the 'Advanced Feature Code' page, blind transfer should be enabled.
- If B hears continuous busy tones after he dials the extension number of C, it means the call has timed out.

3.4.2 Attended Transfer

Attended transfer is a call transfer in which the transferring party connects the call to a third party after he confirms that the third party agrees to answer the call.

Example: A gives a call to B and B wants to attend and transfer the call to C. Operation instructions are as follows:

- 3.2.1.1.1.1.5 A dials the extension number of B;

-
- 3.2.1.1.1.1.6 The extension of B rings, and B picks up the phone. Then A and B go into conversation;
 - 3.2.1.1.1.1.7 B presses the flash button (or flash hook), and then dials the extension number of C (end up with #).

Then one of the following situations will happen:

- a. If C answers the call and accepts the transfer, B will hand up the phone, and then C and A go into conversation.
- b. If the extension of C cannot be reached or if C rejects the call, B needs to press the flash button to resume the call with A.

3.5 Function of Flash-hook

Assume A and B are in a call conversation:

If B presses the flash hook, and then dials the number of C, B, and C go into conversation and meanwhile the call between B and A is kept holding.

Then, if B presses the flash hook and dials 1, the conversation will switch back to A and B; if B presses the flash hook and dials 2, the conversation will switch to B and C; if A presses the flash hook and dials 3, the conversation will switch to A, B and C (which is named **'three-way calling'**).

3.6 Description of Feature Code

The device provides convenient telephone functions. Connect a telephone to the FXS port and dial a specific feature code, and you can query corresponding information.

Code	Corresponding Function
*158#	Dial *158# to query LAN IP
*114#	Dial *114# to query the phone number of a FXS port
*115#	Dial *115# to query the phone number of a FXS port group
*168#	Dial *168# to query the register status of a FXS port
*154#	Dial *154# to remove login limit

150	Dial *150*1 to set IP address as static IP address; dial *150*2 to set IP address as DHCP IP address
152	Dial *152* to set IPv4 address, for example: Dial *152*192*168*1*10# to set IPv4 address as 192.168.1.10
153	Dial *153* to set IPv4 netmask, for example: Dial *153*255*255*0*0*# to set IPv4 netmask as 255.255.0.0
156	Dial *156* to set IPv4 gateway, for example: Dial *156*192*168*1*1# to set IPv4 gateway as 192.168.1.1
*170#	Dial *170# to increase the sound volume of a FXS port
*171#	Dial *171# to decrease the sound volume of a FXS port
165	Dial *165*000000# to restore username/password and network configuration to factory defaults
166	Dial *166*000000# to reset factory configuration
*111#	Dial *111# to restart the device
47	Dial *47* to allow call through IP address, for example: Dial *47*192*168*1*1# to allow to call through the IP address of 192.168.1.1
*51#	Dial *51# to enable the call waiting service
*50#	Dial *50# to disable the call waiting service
87	Dial *87* to trigger blind transfer, for example: Dial *87*8000#, and you can blind transfer to the extension number 8000
72	Enable unconditional call forwarding service. Example: Dial *72*8000, and calls will be unconditionally forwarded to extension number 8000
*73#	Disable unconditional call forwarding service
90	Enable the 'call forwarding on busy' service. Example: Dial *90*8000, and calls will be forwarded to extension number 8000 when the called number is busy
*91#	Disable the 'call forwarding on busy' service
92	Enable the 'call forwarding on no reply' service. Example: Dial *92*8000, and calls will be forwarded to extension number 8000 when there is no reply from the called number

*93#	Disable the 'call forwarding on no reply' service
*78#	Enable the 'No Disturbing' service
*79#	Disable the 'No Disturbing' service
*200#	Dial *200# to access voicemail
*#	Dial *# in 2 seconds to hold the call (back the call by ""hook flash" or dial *#)
##	Dial *# to release the current call and restore inactive call

Note:

A voice prompt indicating successful configuration will be played after each configuration procedure. Please do not hang up the phone until hearing the prompt.

3.7 Send or Receive Fax

3.7.1 Fax Mode Supported

- T.38 (IP-based)
- T.30 (Pass-Through)
- Adaptive Fax Mode (automatically match with the peer fax mode)

3.7.2 Explanation of T.38 and Pass-through

T.38 is an ITU recommendation for allowing transmission of fax over IP networks in real time. Under the T.38 mode, analog fax signal is converted into digital signal and fax signal tone is restored according to the signal of peer device. Under the T.38 mode, fax traffic is carried in T.38 packages.

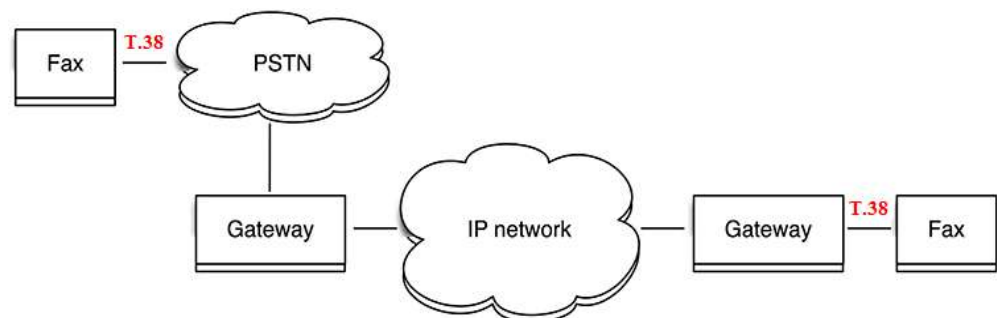

T 3.0 (Pass-through): Under the pass-through mode, fax signal is not converted and fax traffic is carried in RTP packets. It uses the G.711 A or G711 U codec in order to reduce the damage to fax signal.

Adaptive Fax Mode: automatically match with the fax mode of the peer device.

3.8 Function of RST Button

Press the RST button of the device for a moment, the running indicator will turn from “slow flashing” into “no flashing” , and then turn into “slow flashing” again. That means the device has been restored back to factory setting.

3.9 Query IP Address and Restore Default Setting

Query IP Address:

After connecting a telephone to the FXS port, you can dial *158# to query the IP address of LAN port and dial *159# to query the IP address of WAN port.

Reset Password:

- | | |
|--------------|---|
| 3.2.1.1.1.8 | On the “Security Passwords” page of the Web interface, you can reset username and password. |
| 3.2.1.1.1.9 | You can also reset password through the Cloud platform. |
| 3.2.1.1.1.10 | Connect a telephone with the device, and then dial *165*000000# to restore username/password and network configuration to factory defaults. |

Restore Device to Default Settings:

- Connect a telephone with the device, and then dial *166*000000# to restore all configurations to factory defaults.
- Press the RST button for a moment, the running indicator will turn from “slow flashing” into “no flashing” , and then become “slow flashing” again. That means all configurations of the device has been restored to factory defaults.

-
- On the “Tools Factory Reset” page of Web interface, click **Apply** to restore the configurations of the device to factory defaults.

4 Configurations on Web Interface

4.1 Access WEB Interface

First, users connect the device to the network and refer to the network topology diagram for connection. Then refer to the chapter *3 Basic Operation* and dial *158# to query the IP address of the device.

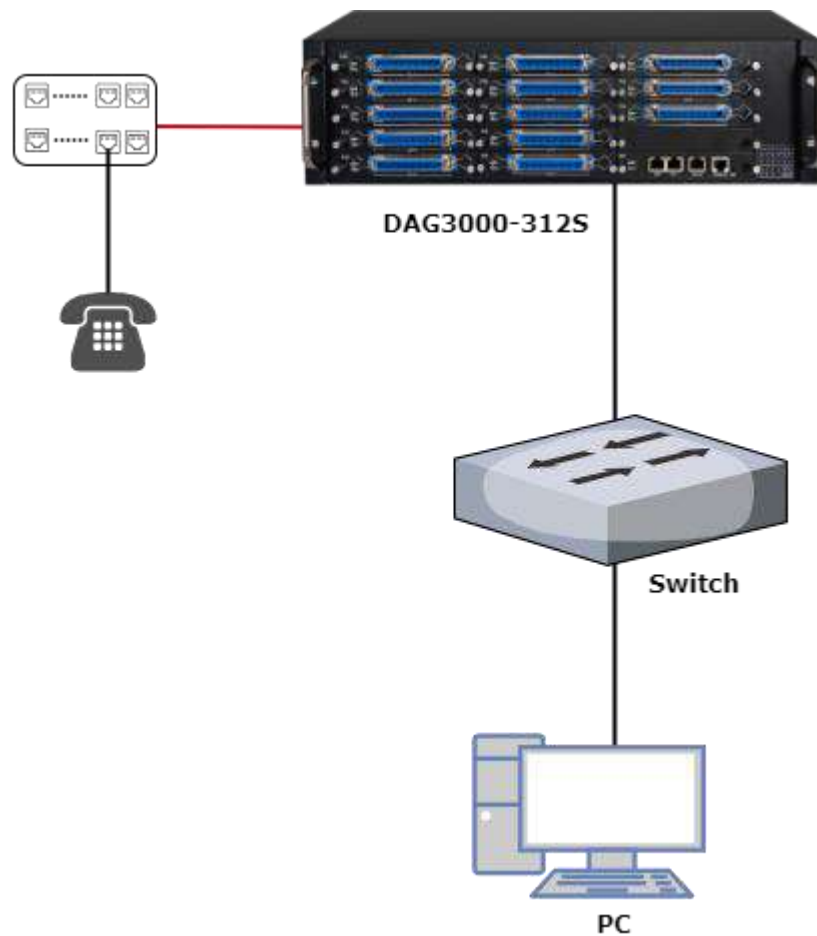

4.1.1 Preparation for Login

To log in the Web Management System of the gateway, firstly, you need to modify the IP address of PC which is used to access the gateway and to make it at the same network segment with the gateway.

1. On the PC, click '**Network (or Ethernet) → Properties**'.

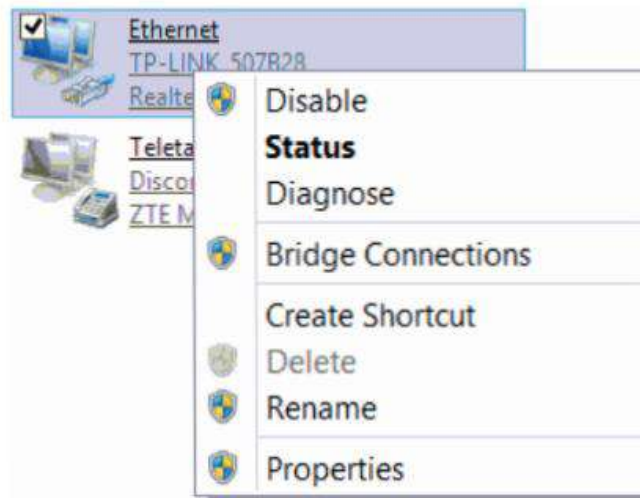

2. Double-click '**Internet Protocol Version 4 (TCP/IPv4)**'.

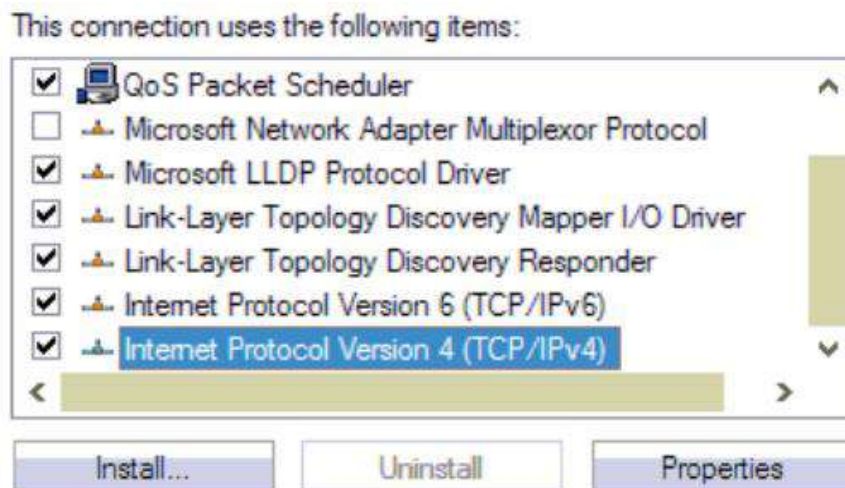

3. Select '**Use the following IP address**', and then enter an available IP address '**192.168.11.XXX**' which is at the same network segment with '**192.168.11.1**'.

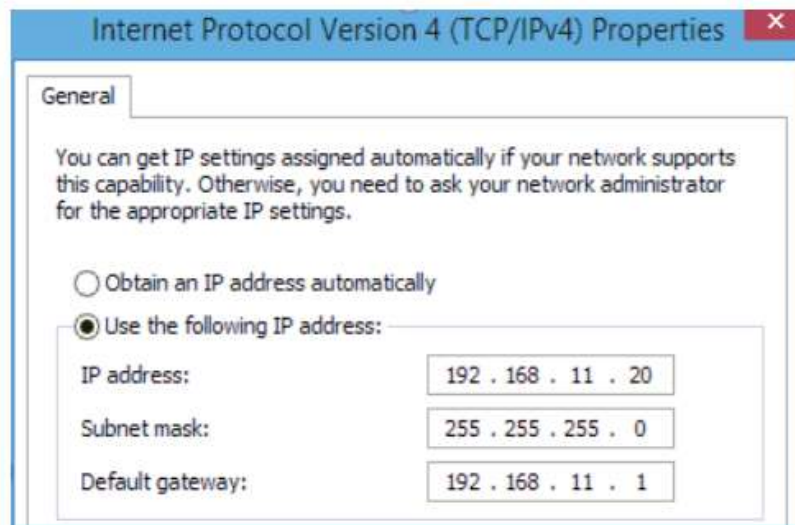

Then, check the connectivity between the PC and the device. Click **Start Run** of PC and enter **cmd** to execute 'ping 192.168.11.1' to make sure the IP address is pingable.

4.1.2 Log in WEB

Open a web browser and enter the IP address (the default IP is 192.168.11.1). Then the login GUI will be displayed.

It is suggested that you should modify the username and password for security consideration.

Figure-Login GUI

Both the default username and password are admin. Click Login to enter the web interface.

4.2 Navigation Tree

The web management system of the device consists of the navigation tree and configuration interfaces with more details.

Choose a node of the navigation tree to enter a configuration interface.

Figure-Navigation Tree of Web Interface

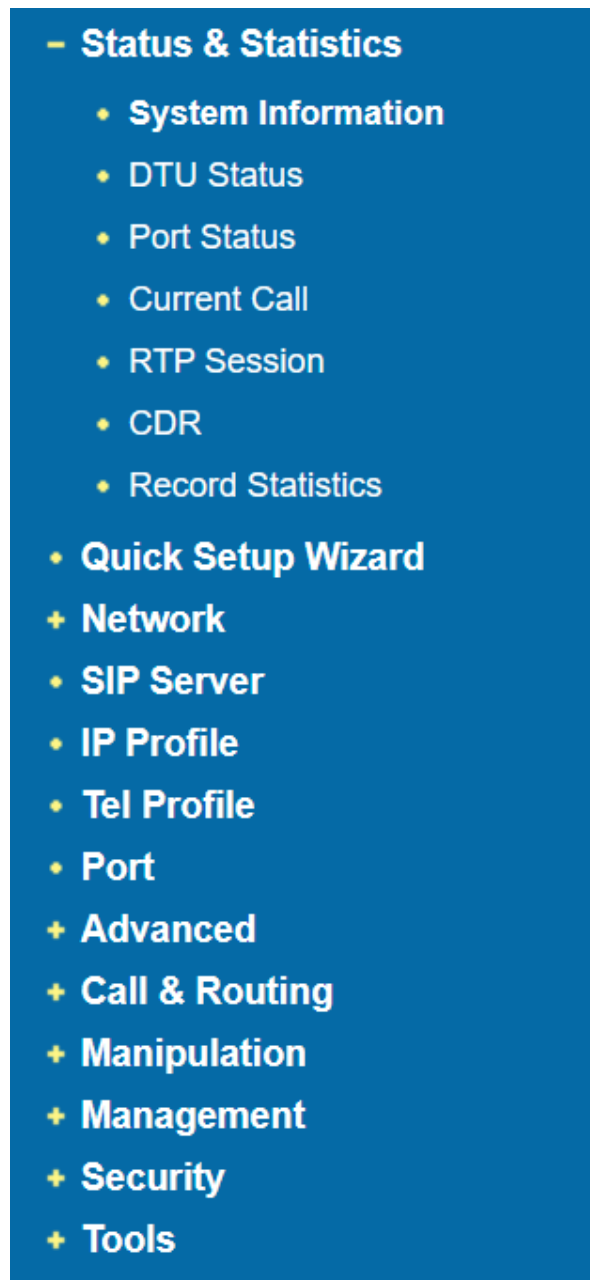

4.3 Status & Statistics

The 'Status & Statistics' menu mainly displays all kinds of information. It includes the following sub-menus: System Information, DTU Status, Port Status, Current Call, RTP Session, CDR and Record Statistics.

4.3.1 System Information

Log in the Web interface, and then click **Status & Statistics -> System Information**, and the following page will be displayed. On the page, you can view the information of device ID, MAC address, IP addresses, version information, server register status and so on.

Figure-System Information

System Information			
Device ID	7624-9558-7534-1985		
MAC Address	F8-A0-76-49-51-85		
IP Address	172.28.36.185	255.255.0.0	DHCP
	172.28.1.1		
DNS Server	8.8.8.8	4.4.4.4	
Cloud Register Status	Not Registered		
System Uptime	0 h: 17 m: 39 s		
System Time	2023-11-08 21:27:59		
Traffic Statistics	Received 6128393 bytes	Sent 4923299 bytes	
Usage of Flash	67 %(5332992 / 7929856) bytes		
Usage of Backup Flash	28 %(15986688 / 55427072) bytes		
Usage of RAM in Linux	35 %(44896256 / 126689280) bytes		
Usage of RAM in AOS	53 %(17989632 / 33546240) bytes		
Current Software Version	DAG3000-312S 2.83.11.27 PCB 36 LOGIC 0 BIOS 1, 2023-11-09 11:03:06		
Backup Software Version	DAG3000-312S 2.83.11.27 PCB 36 LOGIC 0 BIOS 1, 2023-11-09 10:34:48		
DSP Version	libv1.85 ARM_32_13 Jan 13 2022 17:30:22		
U-BOOT Version	11		
Kernel Version	17		
Root FS Version	15		
FS Version	16		
Hint Language	English		

<p>IP Address</p>	<p>There are three kinds of IP address for the WAN port and LAN port:</p> <p>DHCP: Obtain IP address automatically. The gateway is regarded as a DHCP client, which sends a broadcast request and looks for a DHCP server from the LAN to answer. Then the first discovered DHCP server automatically assigns an IP address to the gateway from a defined range of numbers.</p> <p>Static IP Address: Static IP address is a semi-permanent IP address and remains associated with a single computer over an extended period of time. This differs from a dynamic IP address, which is assigned <i>ad hoc</i> at the start of each session, normally changing from one session to the next.</p> <p>If you choose static IP address, you need to fill in the following information:</p> <ul style="list-style-type: none">● IP Address: the IP address of the WAN port of the device;● Subnet Mask: the netmask of the router connected the device;● Default Gateway: the IP address of the router connected the device; <p>PPPoE: PPPoE is an acronym for point-to-point protocol over Ethernet, which relies on two widely accepted standards: PPP and Ethernet. PPPoE is a specification for connecting the users on an Ethernet to the Internet through a common broadband medium, such as a single DSL line, wireless device or cable modem. PPPOE IP address refers to IP address assigned through the PPPoE mode.</p> <p>If you choose PPPoE, you need to fill in to fill in the following information:</p>
--------------------------	---

	<ul style="list-style-type: none"> • Username: the account name of PPPoE • Password: the password of PPPoE • Server Name: the name of the server where PPPoE is placed
DNS Server	IP addresses of primary DNS server and standby DNS server are displayed.
Cloud Register Status	Whether the device is registered to cloud or not.
System Uptime	The running time of the device since it is powered on.
System Time	The NTP synchronization time of the device
Traffic Statistics	Total bytes of message received and sent by device.
Usage of Flash	Detailed usage of Flash memory
Usage of Backup Flash	The memory usage of the backup partition
Usage of RAM in Linux	detailed RAM usage of Linux core
Usage of RAM in AOS	Detailed RAM usage of AOS
Current Software Version	The software version that runs on the device. Model name, version number and the software development date are displayed.
Backup Software Version	Backup software is for the purpose of backup. When the current software fails, the backup software version will work.
U-BOOT Version	U-boot version
Kennel version	Linux Kennel version
Root FS Version	Root file system version
FS Version	File system version
Hint Language	The current language of the DAG device

4.3.2 DTU Status

The following figures on **Status & Statistics->DTU Status** page shows the DTU card information and DTU channel information, and users can view the connection status of DTU through this page.

DTU Card Information				
DTU No.	Link Status	DSP Status	License	Temperature
DTU 0	Connected	Success	40	53°C
DTU 1	Connected	Success	40	62°C
DTU 2	Connected	Success	40	51°C
DTU 3	Connected	Success	40	62°C
DTU 4	Connected	Success	40	50°C
DTU 5	Connected	Success	40	62°C
DTU 6	Connected	Success	40	60°C
DTU 7	Connected	Success	40	51°C
DTU 8	Connected	Success	40	60°C
DTU 9	Connected	Success	40	62°C
DTU 10	Connected	Success	40	49°C
DTU 11	Connected	Success	72	58°C
DTU 12	UnConnected	Fault	---	---

DTU Channel Information					
DTU No.	Active	Idle	DSP Cap	Port Range	Version
DTU 0	0	26	1080	2048-2303	board1.3-5.3-29
DTU 1	0	26	1080	2304-2559	board1.3-5.3-29
DTU 2	0	26	1080	2560-2815	board1.3-5.3-29
DTU 3	0	26	1080	2816-3071	board1.3-5.3-29
DTU 4	0	26	1080	3072-3327	board1.3-5.3-29
DTU 5	0	26	1080	3328-3583	board1.3-5.3-29
DTU 6	0	26	1080	3584-3839	board1.3-5.3-29
DTU 7	0	26	1080	3840-4095	board1.3-5.3-29
DTU 8	0	26	1080	4096-4351	board1.3-5.3-29
DTU 9	0	26	1080	4352-4607	board1.3-5.3-29
DTU 10	0	26	1080	4608-4863	board1.3-5.3-29
DTU 11	0	26	1080	4864-5119	board1.3-5.3-29

Refresh

4.3.3 Port Status

On the **Status & Statistics ->Port Status** page, users can view the port status of each FXS port or port group.

The following figure shows the registration information of ports and port groups. Users can view the registration status of each port and port group of the device through this page. This page only displays some of the port information!

Figure-Registration Status of Each FXS Port or Port Group

Port					
Port No.	Type	SIP User ID	User Status	Port Status	Call Status
0	FXS	---	---	OnHook	Idle
1	FXS	---	---	OnHook	Idle
2	FXS	---	---	OnHook	Idle
3	FXS	---	---	OnHook	Idle
4	FXS	---	---	OnHook	Idle
5	FXS	---	---	OnHook	Idle
6	FXS	---	---	OnHook	Idle
7	FXS	---	---	OnHook	Idle
8	FXS	---	---	OnHook	Idle
9	FXS	---	---	OnHook	Idle
10	FXS	---	---	OnHook	Idle
11	FXS	---	---	OnHook	Idle
12	FXS	---	---	OnHook	Idle
13	FXS	---	---	OnHook	Idle
14	FXS	---	---	OnHook	Idle
15	FXS	---	---	OnHook	Idle
16	FXS	---	---	OnHook	Idle
17	FXS	---	---	OnHook	Idle
18	FXS	---	---	OnHook	Idle
19	FXS	---	---	OnHook	Idle
20	FXS	---	---	OnHook	Idle
21	FXS	---	---	OnHook	Idle
22	FXS	---	---	OnHook	Idle
23	FXS	---	---	OnHook	Idle

Select Slot: ▼

Port Group			
Group	Port	SIP User ID	User Status
---	---	---	---

SIP User status:

- ▶ Registered: the port or port group is registered to SIP server successfully;
- ▶ Unregistered: the port or port group fails to be registered to SIP server.

4.3.4 Current Call

On the **Status & Statistics->Current Call** page, users can view the call statistics of each port of the device, including: port, type, source, destination, connected time, and duration.

Figure-Current Call

Port	Type	Source	Destination	Connected Time	Duration(s)
--	--	--	--	--	--

Select Slot:

4.3.5 RTP Session

On the **Status & Statistics-> RTP Session** page, users can view the real-time RTP session information, including: port, source, destination, payload type, packet period, local port, peer IP, peer port, sent packets, received packets, lost packets rate, jitter, and duration.

Figure-Real-time RTP Session Information

Port	Source	Destination	Payload Type	Packet Period	Local Port	Peer IP	Peer Port	Sent Packets	Recv Packets	Lost Packets Rate(%)	Jitter	Duration(s)
--	--	--	--	--	--	--	--	--	--	--	--	--

Select Slot:

4.3.6 CDR

CDR (Call Detail Record): is a data record produced by a telephone exchange or a telecommunication device, which contains the details of a telephone call that passes through the device.

On the **Status & Statistic->CDR** page, users can enable the CDR function and view the details of all calls through the FXS ports of the device. Users can also export, filter, or clear the CDRs.

Figure-CDRs of FXS Ports

The screenshot shows a 'CDR Report' interface with the following elements:

- Enable CDR:** Radio buttons for 'No' and 'Yes' (selected), with a 'save' button.
- Port:** A dropdown menu set to 'All'.
- Call State:** A dropdown menu set to 'All'.
- Source:** An empty text input field.
- Destination:** An empty text input field.
- CDR Oper:** An 'Export' button.
- Filter:** A 'filter' button.
- Clear:** A 'Clear' button.
- Enable Advanced Option:** Radio buttons for 'No' (selected) and 'Yes'.
- Summary:** 'Total : 0 Entry - 50 Entry/Page - 1/1' and 'Page 1' dropdown.
- Table Header:** A row of columns: Port, Start Time, Answer Time, Direction, Source, Destination, PeerIP, Codec, Reason, Duration (s).

Parameter	Explanation
Enable CDR	whether CDR is enabled; check Yes, the CDRs will be displayed after the call; or the CDRs will not be displayed after the call ends
Port	Select one port or all ports to filter CDRs
Call State	Filter CDRs according to the call state, users can select All, Not Answer, Complete and Fail
Source	Filter CDRs according to the caller
Destination	Filter CDRs according to the callee
Export	Export the CDRs to local computer (file name is cdr.txt)
Filter	Filter the CDRs according to port, call state, caller and callee
Clear	Clear all the CDRs
Enable Advanced Option	When the advanced option is enabled, it will display the peer port, local IP, local port, end code, RTP send, RTP received, RTP loss rate, jitter

4.3.7 Record Statistics

On the **Status & Statistic->Record Statistics** page, record statistics including server status, count of current records, count of no response, count of server return errors, count of record starts, count of record startAck, count of record stops and count of stopAck are displayed.

Figure-Record Statistics

Record Statistics							
Server Stat	Current Records	No Responses	Server Return Error	Start	StartAck	Stop	StopAck
Not Config	0	0	0	0	0	0	0

No Response Statistics	
Link Dect NoRsp Cnt	0
Start Time Out Cnt	0
Rel Call Before StartAck	0
Stop Time Out Cnt	0

4.4 Quick Setup Wizard

Quick setup wizard guides user to configure the device step by step. User only needs to configure network, SIP server and SIP port in the Quick Setup Wizard interface. Basically, after these three steps, users can make voice call via the device.

For the configurations of network, SIP server and SIP port, please refer to **4.5**, **4.6** and **4.9**.

4.5 Network

4.5.1 Local Network

On **Network->Local Network** page, users can configure the IP protocol, WAN Dual Mode, network configuration, manage address, and DNS server address of the device.

The device supports both IPv4 and IPv6 IP protocols and two network configuration methods (DHCP or static IP address).

Figure-Local Network Setting

Note: The device must restart to take effect.

Save

Parameter	Explanation
IP Protocol	There are 2 IP protocols the device supported, IPv4 or IPv6
WAN Dual Mode	The working mode for GE0/GE1. It supports separation, bonding, and bridge
Obtain an IP address automatically	The device obtains IP address through DHCP server

Use the following IP address	Set a static IP address for the device
WAN MTU	Set the MTU value of WAN port, and the valid range is from 512-1500.
Obtain DNS server address automatically	The device obtains DNS server address through DNS server
Use the following DNS server address	Set a static DNS server address for the device
Primary DNS Server	Primary DNS Server
Secondary DNS Server	Set secondary DNS server for the device

4.5.2 VLAN (Virtual Local Area Network)

In order to control the impacts brought by broadcast storms, you can divide the local-area network into three VLAN groups, including data VLAN, voice VLAN and management VLAN on the **Network-> VLAN** page.

Management VLAN transmits management-related packets, such as packets of SNMP, TR069, Web and Telnet, while voice VLAN transmits the signals and voices produced by the device itself. Data VLAN transmits data packets.

Figure-Configure VLAN

NO.	Type	VLAN ID	Priority	Network Mode	IP Address	Subnet Mask	Default Gateway	DNS1	DNS2	MTU	LAN Port/State
---	---	---	---	---	---	---	---	---	---	---	---

VLAN

VLAN NO.

Data
 Voice
 Mngt

VLAN ID(1 - 4094)

Priority(0 - 7)

Network Configuration

Obtain an IP address automatically
 Use the following IP address

IP Address
 Subnet Mask
 Default Gateway

DNS Server

Obtain DNS server address automatically
 Use the following DNS server address

Primary DNS Server
 Secondary DNS Server

MTU

Table-Explanation of VLAN Parameters

Parameter	Explanation
VLAN1/VLAN2/VLAN3	The device supports three VLANs at most. Please enable VLAN according to actual needs.
Data/Voice/Management	Select what kind of messages are allowed to go through this VLAN. For example, if the checkbox on the left of data is selected, it means data messages are subject to the following network setting of this VLAN.
VLAN ID(1-4094)	Set an ID to identify a VLAN based on 802.1Q protocol. Range is from 1 to 4094.
Priority (0-7)	Set the priority of a VLAN based on 802.1P protocol. 0 is the highest priority.

Obtain an IP address automatically	The device obtains IP address through DHCP server
Use the following IP address	Set a static IP address for the device
IP Address	Set the IP address of the VLAN interface
Subnet Mask	Set the subnet mask of the VLAN interface
Default Gateway	Set the default gateway address of the VLAN interface
Obtain DNS server address automatically	The device obtains DNS server address through DNS server
Use the following DNS server address	Set a static DNS server address for the device
Primary DNS Server	Set a primary DNS server address for the device
Secondary DNS Server	Set a secondary DNS server address for the device
MTU	Set the MTU value of the VLAN interface

[Note]: After the configurations are finished, you need to restart the device for the configurations to take effect.

4.5.3 DHCP Option

When the device works as a DHCP client and applies for an IP address, DHCP server will return packets which include an IP address as well as configuration information of enabled option fields.

The following is the meaning of the option fields involved in the device (that means the following option fields are enabled, DHCP server will return information of corresponding option fields):

- Option 15: to set a DNS suffix;
- Option 42: to specify NTP server;

-
- Option 60: to define VCI (vendor class identifier) of device on the DHCP server;
 - Option 66: to specify TFTP server which will assign software version to device;
 - Option 120: to fetch SIP server address;
 - Option 121: to obtain classless static route. The device will add these static routes to the static route table after it fetches them from DHCP server.

Figure-Configure DHCP Option

DHCP Option	
Option 15 (Domain Name)	<input type="text"/>
Option 42 (NTP Servers)	<input type="checkbox"/> Enable
Option 60 (Class Identifier)	<input type="text"/>
Option 66 (TFTP Server)	<input type="checkbox"/> Enable
Option 120 (SIP Server)	<input type="checkbox"/> Enable
Option 121 (Classless Static Route)	<input type="checkbox"/> Enable

Note: The device must restart to take effect.

Save

Network Interface: choose which VLAN to send request to DHCP server (or to receive information from DHCP server).

4.5.4 QoS

The device can label QoS priority on the IP messages it sends out, so as to resolve network delay or network congestion. Meanwhile, the device can give different QoS tags for management-related packets of Web/Telnet, voice packets and signal packets.

Figure-QoS

Qos Config

DSCP code point is used for diffserv setting. It utilizes the first 6 bits of IP ToS. The default values are EF(184), AF1(1),AF2(2), AF3(3), AF4(4), BE(0). You can use different DSCPs for voice or data based on the network provider.

Set DSCP Code/IP ToS Enable

Manage(WEB/Telnet):

Voice Packet:

Signal Packet:

4.5.5 ARP

ARP is address resolution protocol, which helps to get the MAC address of a device through its IP address. Under TCP/IP network environment, each host is assigned with a 32-bit IP address, but MAC address needs to be known for message transmission in the physical network. In the above case, ARP can help convert IP address into MAC address.

Figure-ARP

ARP Parameter		
Type	IP Address	MAC Address
<input type="radio"/> Static <input checked="" type="radio"/> Dynamic		
<input type="checkbox"/>	172.27.53.66	F8-E4-3B-5A-9D-3D
<input type="checkbox"/>	172.27.0.157	F8-A0-3D-5A-62-9D
<input type="checkbox"/>	172.27.0.121	F4-4D-30-F2-26-6A
<input type="checkbox"/>	172.27.12.10	F8-A0-3D-59-61-F2
<input type="checkbox"/>	172.27.7.77	70-B5-E8-71-F8-3E
<input type="checkbox"/>	172.27.0.183	7C-BA-CC-33-03-62
<input type="checkbox"/>	172.27.0.150	70-B5-E8-75-48-E3
<input type="checkbox"/>	172.27.1.1	F8-A0-3D-5A-63-59

Total: 8 Entry Page 1 ▼

4.6 SIP Server

SIP server is the main component of SIP/IP network and is responsible for establishing all SIP calls. SIP server is also called SIP proxy server or register server. Both IPPBX and softswitch can act as the role of SIP server.

Figure-Configure SIP Server Information

SIP Server

SIP Server

SIP Server

SIP Server Port (Default: 5060)

Registration Expires (Default: 300) s

Heartbeat Enable

Primary Outbound Proxy

Primary Outbound Proxy Address

Primary Outbound Proxy Port

Secondary Outbound Proxy

Secondary Outbound Proxy Address

Secondary Outbound Proxy Port

Registration

Re-registration Percent(Expires)(0: means random, range: 25%-75%)

Retry Interval when Registration failed s

Registration Limit (counts/time, time: 0 means unlimited) / s

Send SIP Unregistration Request when the Device Restart Enable

MOH Enable

MOH Dial Number

SIP Transport Type

Local SIP Port

Use Random Port Enable

SIP UDP/TCP Local Port

Save

Table-Parameter Explanation of SIP Server

Parameter	Explanation
SIP Server	The IP address or domain name of the SIP server. It is provided by service provider or system admin.
SIP Server Port (Default: 5060)	The service port of the SIP server. It is 5060 by default.
Registration Expires (Default: 300)	It is used to avoid excessively frequent registrations. When the time that is set expires, the device will send register request to the SIP server. The time is 300s by default.
Heartbeat	Heartbeat is used to check the connection between the device and SIP server.
Primary Outbound Proxy Address	The IP address or domain name of primary outbound proxy server, which is provided by service provider.
Primary Outbound Proxy Port	The service port of the primary outbound proxy server.
Secondary Outbound Proxy Address	The IP address or domain name of secondary outbound proxy server, which is provided by service provider.
Secondary Outbound Proxy Port	The service port of the secondary outbound proxy server.
Re-registration Percent (Expires) (0: means random, range: 25%-75%)	Within the specified interval, the registration duration * re-registration percent, the terminal will resend the registration request to the server (default is 0, which means random)
Retry Interval when Registration failed	The retry interval after a registration fails. Default: 30s

Registration Limit (counts/time, time: 0 means unlimited)	The number of registrations per second (0 means unlimited)
Send SIP Unregistration Request when the Device Restart	All SIP accounts are logged out and then re-registered after the device is rebooted
MOH	The MOH (Music on Hold) feature provides music play to callers when their call is placed on hold. When enabled, users can configure the number to call on hold.
MOH Dial Number	Initiating a call to a set number after the call is placed on hold
SIP Transport Type	The way of SIP-based transmission. It can be UDP, TCP, TLS or Automatic. Default: UDP.
Use Random Port	If this parameter is selected, the local port of the device for using SIP services is chosen by random.
SIP UDP/TCP Local Port	The UDP/TCP port of device for using SIP services. Default SIP UDP/TCP local is 5060.

Usually, SIP server does not participate in media processing. Under SIP network, media always use end-to-end negotiating. Simple SIP server is only responsible for the establishment, maintenance and cleaning of sessions, while relatively-complex SIP server (SIP PBX) not only provides basic calling/RTP and commutation support, but also offers rich services such as Presence, Find-me and Music On Hold. Some customers may install gateways and work with various SIP/medial systems. SIP server based on Linux platform, such as: Kamailio/OpenSIPS, Asterisk/FreePBX, FreeSWITCH, VoS, Mera etc. SIP server based on windows platform, such as: 3CX, Brekeke, VoIPswitch etc. Carrier-grade soft switch platform, such as Cisco, Huawei, ZTE etc.

4.7 IP Profile

IP Profile												
<input type="checkbox"/>	Index	Description	SIP Server	SIP Server Port	Registration Expires	Heartbeat	Primary Outbound Proxy Address	Primary Outbound Proxy Port	Secondary Outbound Proxy Address	Secondary Outbound Proxy Port	DTMF Method	Preferred Vocoder
<input type="checkbox"/>	0	default	172.28.4.235	5090	300	Disable	---	5060	---	5060	RFC2833	G.711U

IP profile is mainly consisting of a series of IP related parameters include SIP server, outbound proxy, DTMF, codecs etc. which are used to configure different parameters for each FXS port.

4.8 Tel Profile

Tel Profile												
<input type="checkbox"/>	Index	Description	Work Mode	Voice Output Mod	Config Mode(Gain)	Tx Gain(P->PSTN)	Rx Gain(FSTN->IP)	Fax Mode	ECM	Rate	Tone Detection by	Switch into Fax Mode When Detected CNG or CED
<input type="checkbox"/>	0	default...	Voice and Fax	Telephone	Basic	+4dB	0dB	Adaptive	Disable	14400bps	Local	Disable

Note: The configuration will be synchronized to default TelProfile

Tel profile is mainly consisting of a series of line related parameters include FAX, gain value etc. which are used to configure different parameters for each FXS port.

4.9 Port

A unique SIP account used for registration can be configured for each FXS port of device. Parameters of the SIP account include port number, whether to register, primary display name, primary SIP user ID, primary Authenticate ID, primary Authenticate password, off-hook auto-dial number, caller ID and so on.

Figure-Configure SIP Account for Port Registration

Port														
Port	IP Profile	Tel Profile	Index	Display Name	SIP User ID	Authenticate ID	Offhook Auto-Dial	DND(Do Not Disturb)	Caller-ID	CFU	CFB	CFNRy	Call Waiting	Play Call Waiting Tone
---	---	---	---	---	---	---	---	---	---	---	---	---	---	---

Select Slot:

Port Add

Slot	0 ▼
Port	0 ▼
Disable Port	<input type="checkbox"/>
Registration	<input checked="" type="checkbox"/> Enable
IP Profile	0 <default> ▼
Tel Profile	0 <default> ▼
Display Name	<input type="text"/>
SIP User ID	<input type="text"/>
Authenticate ID	<input type="text"/>
Authenticate Password	<input type="text"/>
Offhook Auto-Dial	<input type="text"/>
Auto-Dial Delay Time	<input type="text"/> s
DND(Do Not Disturb)	<input type="checkbox"/> Enable
Caller-ID	<input checked="" type="checkbox"/> Enable
Number for CFU(Call Forwarding Unconditional)	<input type="text"/>
Number for CFB(Call Forwarding Busy)	<input type="text"/>
Number for CFNRy(Call Forwarding No Reply)	<input type="text"/>
Call Waiting	<input type="checkbox"/> Enable
Play Call Waiting Tone	<input type="checkbox"/> Enable
Call Waiting Send CID	<input type="checkbox"/> Enable

Table-Explanation of Parameters Related to SIP Registration

Parameter	Explanation
Slot	The Slot corresponding to this account
Port	The FXS port corresponding to this account
Disable port	Whether to disable port temporally

Registration	Whether to enable registration for the port
IP Profile	Assign IP profile (which need to be created in advance)
Tel Profile	Assign Tel profile (which need to be created in advance)
Display name	Description of SIP account. It is used to identify the SIP account.
SIP User ID	User ID of the SIP account, which is provided by VoIP service provider (ITSP) for registration. Usually, it is in the form of digits similar to phone number or an actual phone number.
Authenticate ID	SIP service subscriber' s authenticate ID used for authentication of registration. It can be identical to or different from SIP User ID.
Authenticate Password	SIP service subscriber' s authenticate ID used for authentication of registration
Offhook Auto-Dial	An extension or phone number is pre-assigned here so that the number is automatically dialed as soon as user picks up the phone
Auto-Dial Delay Time	How long the auto-dial number is prolonged. If it is set as 3s, the auto-dial number is dialed after 3 seconds passed.
DND (Do Not Disturb)	the phone won' t receive any calls if this feature is enabled
Caller ID	Enable or disable caller ID for corresponding port. If it is disabled, the caller ID for the calls through the port won' t be displayed.

Number for CFU	Call forward unconditional. All incoming calls will be forwarded to pre-assigned number automatically
Number for CFB	Call forward on busy. If the line is busy, the call will be forwarded to pre-assigned number automatically
Number for CFNRy	Call forward no reply. If the call is not answered, the call will be forwarded to pre-assigned number automatically
Call Waiting	If call waiting is enabled, a special tone is sent if another caller tries to reach you
Play Call Waiting Tone	If call waiting tone is enabled, caller will hear special tone.
Call Waiting Send CID	When enabled, caller ID is displayed during call waiting

4.10 Advanced

4.10.1 Line Parameter

On the **Advanced->Line parameter** page, you can configure FXS parameters which include for call progress tone, auto gain control, fax parameters and so on.

Line Parameter

Call Progress Tone	CHINA
Ring Back Tone	450,180,450,630,1000,4000,0,0
Busy Tone	450,180,450,630,350,350,0,0
Dial Tone	450,180,450,630,0,0,0,0
Call Waiting Tone	
Call Waiting Tone Duration	800 ms
Call Waiting Tone Gap	2000 ms
Call Waiting Tone Repeat Count	5
Auto Gain Control	
IP->PSTN	<input type="checkbox"/> Enable
PSTN->IP	<input type="checkbox"/> Enable
DSP Jitter Buffer(Recv) Config Mode	
DSP Jitter Buffer(Recv) Config Mode	Adapter
Buffer Size	20 ms
Line Parameter	
Work Mode	Voice and Fax
Voice Output Mod	<input checked="" type="radio"/> Telephone <input type="radio"/> Headset
Config Mode(Gain)	<input checked="" type="radio"/> Basic <input type="radio"/> Advanced
Tx Gain(IP->PSTN)	+4dB
Rx Gain(PSTN->IP)	0dB
FAX Parameter	
Fax Mode	Adaptive
Include "a=X-fax" Attribute	<input type="checkbox"/> Enable
Include "a=fax" Attribute	<input type="checkbox"/> Enable
Include "a=X-modem" Attribute	<input type="checkbox"/> Enable
Include "a=modem" Attribute	<input type="checkbox"/> Enable
Include "vbd" Parameter	<input checked="" type="checkbox"/> Enable
Include "silenceSupp" Parameter	<input checked="" type="checkbox"/> Enable
ECM	<input type="checkbox"/> Enable
Rate	14400 bps
Tone Detection by	Local
Switch into Fax Mode When Detected CNG or CED	<input type="checkbox"/>

Parameter	Explanation
Call Process Tone	The signal tone standard after a phone is picked up. Choose national standards from the drop-down box. Default value is USA.
Call Waiting Tone	Set the duration, gap and repeat count of call waiting tone
Auto Gain Control	Whether to enable automatic gain control

DSP Jitter Buffer(Recv) Config Mode	It supports two modes, static and adapter
Line Parameter	
Work Mode	<p>To set the FXS ports work in both Voice and Fax mode. There are several configure options:</p> <ul style="list-style-type: none"> • Voice and FAX: to be able to make call and use FAX service • Voice Only: allows to make call only, Fax doesn't work if you connect a fax machine • Fax Only: allows to make Fax call only. <p>POS only: allows to connect POS terminal only</p>
Voice Output Mod	It supports two voice output modes: telephone and headset
Config Mode(Gain)	It can adjust the Tx gain and Rx gain, and supports both basic and advanced configuration modes
FAX Parameter	
Fax Mode	There are three fax modes: T.38, T.30(Pass-through), and Adaptive.
Include "a=X-fax" Attribute	If this parameter is enabled, "a=X-fax" attribute will be carried in SDP
Include "a=fax" Attribute	If this parameter is enabled, "a=fax" attribute will be carried in SDP
Include "a=X-modem" Attribute	If this parameter is enabled, "a=X-modem" attribute will be carried in SDP
Include "a=modem" Attribute	If this parameter is enabled, "a=modem" attribute will be carried in SDP

Include "vbd" Parameter	If this parameter is enabled, "a=gpmid:0 vbd=yes" attribute will be carried in SDP
Include "silenceSupp" Parameter	If this parameter is enabled, "a=silenceSupp:off" attribute will be carried in SDP
ECM	Whether to enable 'Error Correction Mode' (ECM).
Rate	The rate of sending or receiving fax, default value is 14400bps.
Tone Detection by	Fax sound is detected by caller, callee or automatically.
Switch into Fax Mode When Detect CNG or CED	If this parameter is enabled, the system will switch into fax mode when CNG or CED is detected.

4.10.2 FXS Parameter

On the **Advanced->FXS Parameter** page, you can configure FXS parameters which include send polarity reversal, detect hook flash, CID type and so on.

Figure-Configure FXS Parameters

FxsParam

Send Polarity Reversal	<input type="checkbox"/> Enable
Detect Hook Flash	<input checked="" type="checkbox"/> Enable
Min Time	<input type="text" value="100"/> ms
Max Time	<input type="text" value="400"/> ms
Ringing Tone	<input type="text" value="0,0,0,0,0,0"/>
CID Type	<input type="text" value="FSK"/>
Modulation Type	<input type="text" value="BFSK Bel202"/>
Message Type	<input type="text" value="MDMF"/>
Message Format	<input type="text" value="Display Name and CID"/>
Send CID before Ringing	<input type="checkbox"/> Enable
Delay of Sending CID after Ringing	<input type="text" value="500"/> ms
Caller Number Preferred when FXS Call Out	<input type="text" value="Adaptive"/>
CFNRy Timeout	<input type="text" value="33"/> s
SLIC Setting	<input type="text" value="600 Ohm"/>
REN	<input type="text" value="4"/>
Current Threshold(Off-Hook -> On-Hook)	<input type="text" value="10"/>
Current Threshold(On-Hook -> Off-Hook)	<input type="text" value="12"/>
Current of Off-Hook(Non-long Line)	<input type="text" value="20mA"/>
Long Line Support	
Slot	0 1 2 3 4 5 6 7 8 9 10 11 12
Enable	<input type="checkbox"/> <input type="checkbox"/> <input type="checkbox"/> <input type="checkbox"/> <input type="checkbox"/> <input type="checkbox"/> <input type="checkbox"/> <input type="checkbox"/> <input type="checkbox"/> <input type="checkbox"/> <input type="checkbox"/> <input type="checkbox"/> <input type="checkbox"/>

Notes: 1. Voice Output Mode , REN must restart to take effect.
2. Current of Off-Hook must restart to take effect.

Save

Table-Explanation of FXS Parameters

Parameter	Explanation
Send Polarity Reversal	If polarity reversal is enabled, call tolls will be calculated based on the changes in voltage. If polarity reverse is disabled, you need to set the time for offhook detection and call tolls will be calculated starting from the set time.
Detect Hook flash	If 'Detect Hook Flash' is enabled, you need to set a minimum time and a maximum time. If a phone's hook flash is pressed for a time period greater than the set minimum time but less than the maximum time, the action is considered as a 'hook flash' operation. If a phone's hook flash is pressed for more the set maximum time, the action is considered as 'hang up the phone' .
Ringing Tone	Set ringing tone for gateway
CID Type	There are two CID types, namely DTMF and FSK.
Modulation Type	There are two modulation types, namely BFSK Bel202 and CCITT V.23
Message Type	There are two call display types including SDMF and MDMF
Message Format	The call display format in analog phone. It can be "Display Name and CID" , "CID only" , or "Display Name only" ; default value is "Display Name and CID"
Send CID before Ringing	If this parameter is enabled, the device will send Caller ID to phone before ringing, otherwise the caller ID will be displayed after ringing.

Delay of sending CID after Ringing	The time how long the caller ID will be delayed when the caller ID is set to be displayed after ringing. Default value is 500ms.
Caller Number Preferred when FXS Call Out	Users can configure the primary caller number that will be called out to the target number in priority. Users can select Adaptive, Port Account or Port Group Account
CFNRy Timeout	Timeout for 'call forwarding on no answer' service.
SLIC Setting	Impedance matched with analog phone.
REN	The maximum number of extensions that can be connected to a single FXS port. If this parameter is configured, you need to restart the device for the configuration to take effect.
Current Threshold (Off-Hook -> On-Hook) Or Current Threshold (On-Hook -> Off-Hook)	It is used for two conditions. If FXS port connecting with a certain FXS phone, the phone is not under off-hook status, but FXS has detected off-hook. In such condition, users have to set it. If the problem still not be solved, Users may try to set current of off-hook and current of on-hook to 20mA.
Current of Off-Hook (Non-long Line)	Configure current of off-hook, it can be configured with 20, 25, 30, 35, 40mA
Long Line Support	Whether to enable 'Long Analog Extension Line' .

4.10.3 Media Parameter

Media parameters mainly include RTP start port, DTMF parameter, preferred Vocoder, etc.

Figure-Configure Media Parameters

Media Parameter

RTP Start Port: 6144

UDP Checksum Validation: Enable

SRTP Mode: Disable

DTMF Parameter

DTMF Method: RFC2833

RFC2833 Payload Type Preferred(Incoming Call): Remote

RFC2833 Payload Type: 101

DTMF Gain: 0dB

DTMF Send Cadence: 100,100

Send Flash Event: Enable

Send DTMF Tone to Analog When Call in Active: Enable

Preferred Vocoder

	Coder Name	Payload Type	Packetization Time(ms)	Rate(kbps)	Silence Suppression
1	G.711U	0	20	64	Disable
2	G.711A	8	20	64	Disable
3	G.729	18	20	8	Disable
4	G.723	4	30	63	Disable
5					

Prefer Codec: Remote

Save

Table-Explanation of Media Parameters

Parameter	Explanation
RTP Start Port	When 'Use Random Port' is not selected, you need to configure a start port for RTP. Default RTP start port is 8000
UDP Checksum Validation	Choose whether to enable header checksum of UDP

SRTP Mode	Configure whether RTP is encrypted
DTMF Method	Include SINGAL, INBAND and RFC2833
RFC2833 Payload Type Preferred (Incoming Call)	For an incoming call, choose local or remote RFC2833 payload type as the preferred payload type
RFC2833 Payload Type	Local payload value, default value is 101
DTMF Gain	Default value is 0 DB
DTMF Send Cadence	Time interval for DTMF signal transmission, default is 100 ms.
Send Flash Event	If this parameter is enabled, the device will send flash-hook event to remote terminal, and thus user does not need to handle it locally
Send DTMF Tone to Analog When Call in Active	If this parameter is enabled, DTMF tone will be sent to analog phone when there is a call
Coder Name	The device supports G.729, G.711U, G.711A, G.723, G.726-16/24/32/40. When outgoing calls are made, G.729 will be used.
Payload Type	Each kind of coding has a unique load value, refer to RFC3551.
Packetization Time	The time for voice packaging
Rate	Voice data flow rate; It is defaulted by system.
Silence Suppression	Default value is 'disabled' . If this parameter is enabled, VoIP transmission bandwidth can be saved, and meanwhile network congestion can be avoided.
Prefer Codec	Choose local or remote codec as the preferred codec

4.10.4 Service Parameter

Service parameters include timeout for dialing, digitmap, MWI message and so on.

Service Parameter

Timeout for Off-hook	<input type="text" value="10"/>	s
Timeout for Dialing	<input type="text" value="4"/>	s
Timeout for Answer(Outgoing Call)	<input type="text" value="55"/>	s
Timeout for Answer(Incoming Call)	<input type="text" value="55"/>	s
No RTP Detected	<input type="checkbox"/> Enable	
Period without RTP Packet	<input type="text" value="60"/>	s
SUBSCRIBE for MWI(Message Waiting Indicator)	<input type="checkbox"/> Enable	
MWI Subscription Expires(Default: 3600)	<input type="text" value="3600"/>	s
VoiceMail User ID	<input type="text"/>	
Visual MWI Type	<input type="text" value="NEON"/>	
NEON Voltage(75-100V)	<input type="text" value="75"/>	
IP-to-IP Call	<input type="checkbox"/> Enable	
Only Accept Calls from ACL(SIP Server or IP Trunk)	<input type="checkbox"/> Enable	
Anonymous Call	<input type="checkbox"/> Enable	
Reject Anonymous Call	<input type="checkbox"/> Enable	
# as Ending Dial Key	<input checked="" type="checkbox"/> Enable	
# Escape	<input type="checkbox"/> Enable	
Send # when First Dial Number is **	<input checked="" type="checkbox"/> Enable	
Call Confirm Tone	<input type="checkbox"/> Enable	
Howl Tone Interval After Busytone(0:No Send)	<input type="text" value="0"/>	s
Max Call Duration(0:No Limit)	<input type="text" value="0"/>	s
Domain Query Type	<input type="text" value="A Query"/>	
DNS Cache	<input checked="" type="checkbox"/> Enable	
Domain Re-resolution Interval(0-3600,0:No Refresh)	<input type="text" value="0"/>	s
Echo Cancel Tail	<input type="text" value="128"/>	ms
Digit Map		
Match Failed(When the registration is successful)	<input type="text" value="Send to the server"/>	
<pre> [*]T [*][*#] *x.T **x.# [*]xx# *#xx# [*][0-9*#]x[0-9*].x# x.# x.T </pre>		

NOTE: Length of 'Digit Map' should be less than 5120 characters.

Parameter	Explanation
-----------	-------------

Timeout for off-hook	Mainly used to define a timer that when the user is off hook an analog phone without dial any digits
Timeout for dialing	With the help of dialing timeout, you can limit the time between two digits while users are typing the digits of a number through an extension. If the timeout expires, the gateway will consider the dialing has finished and will try to send message to SIP server. Default value is 4 seconds.
Timeout for answer (Outgoing call)	This parameter determines how long the caller party will wait for answer when making outgoing calls through a phone.
Timeout for answer (Incoming call)	This parameter determines how long the phone rings when there are incoming calls
No RTP Detected	If this parameter is enabled, the situation will be detected when there is no RTP packets received during the set time period.
Period without RTP Packet	The time period when there is no RTP packets received.
SUBSCRIBE for MWI (Message Waiting Indicator)	MWI is aimed to notify user that there is new voicemail. It is realized in the way of NOTIFY.
MWI Subscription Expires(Default: 3600)	The expiry time of MWI subscription; Default value is 3600s.
Voicemail User ID	The user ID used to access to voicemail
Visual MWI Type	There are two visual MWI Type, namely NEON and FSK
NEON Voltage(75- 100V)	Set Voltage for NEON, If the voltage is lower than the value set, the LED will not be in flash.

IP-to-IP Call	If this parameter is enabled, user can dial IP address through a phone to call destination gateway.
Only Accept Call from ACL (SIP server or IP Trunk)	If this parameter is enabled, the device only accepts incoming call from SIP server only. Default value is 'not enable' .
Anonymous Call	If this parameter is enabled, 'anonymous' will be included in SIP message. And the calls made by the device are anonymous.
Reject Anonymous Call	If this parameter is enabled, all anonymous calls will be rejected. Default value is 'not disable' .
# as ending Dial Key	If this parameter is enabled, '#' is used as the end mark for dialing.
# Escape	If this parameter is enabled, '#' is considered as a digit of the number that is dialed.
Send '#' when First Dial Number is '*'	If this parameter is enabled, '#' will be sent when first dialed digit is '*' .
Call Confirm Tone	When enabled, the device will play back a ringback tone even if the device does not receive a 180 response
Howl Tone Interval After Busytone(0:No Send)	The time interval for Howler tone after playing Busytone
Max Call Duration(0:No Limit)	When the duration of call is reach the set time, the call will hang up directly (default is 0, 0 means unlimited)
Domain Query Type	Set the query of the domain name, and support three query methods: A query, SRV query and NAPTR query
DNS Cache	When enabled, the device will not initiate domain name query requests to DNS servers during the re-resolution interval.

Domain Re-resolution Interval(0-3600,0:No Refresh)	Configure the domain name re-resolution interval. The range is 0-3600, and 0 means no refresh
Echo Cancel Tail	Configure echo cancellation duration

Digitmap is used for number dialing of calls through FXS ports of the device.

Parameter		Explanation
Supported Objects	Digit	0-9
	T	Timer
	DTMF	A digit, a timer, or one of the symbols of A, B, C, D, #, or *
Range	[]	One or more DTMF symbols enclosed in the [], but only one DTMF symbol can be selected
Range	()	One or more expressions enclosed the (), but only one can be selected
Separator		Separate expressions or DTMF symbols.
Subrange	-	Two digits separated by hyphen (-) which matches any digit between and including the two digits.
Wildcard	x	Matches any digit of 0 to 9
Modifiers	.	Matches 0 or more times of the preceding element
Modifiers	?	Matches 0 or 1 times of the preceding element

4.10.5 SIP Compatibility

SIP parameters include attended transfer trigger, early media, session timer, heartbeat interval and so on.

Figure-Configure SIP Parameters

SIP Compatibility	
RFC3407 Support	<input type="checkbox"/> Enable
Forbid "user=phone"	<input type="checkbox"/> Enable
"From" SIP URI includes "user=phone"	<input type="checkbox"/> Enable
Default Port Display Policy in SIP URL	Hide when the host is Domain
INVITE with "P-Preferred-Identity" Header (RFC3325)	<input type="checkbox"/> Enable
Value of "Refer To" refers to "Contact"	<input type="checkbox"/> Enable
Third Party Do Not Send 18x Response	<input type="checkbox"/> Enable
REFER Delay	<input type="checkbox"/> Enable
Send BYE when Recv REFER Response(Unattended)	<input type="checkbox"/> Enable
Send New REGISTER when Recv 423 Response	<input checked="" type="checkbox"/> Enable
Verify the Contact Header in REGISTER Response	<input checked="" type="checkbox"/> Enable
Cseq Start with 1	<input type="checkbox"/> Enable
Forbid Invalid m=line in reINVITE	<input type="checkbox"/> Enable
SIP Message with ID Header	MAC
ID Header Separator	None
Call Waiting Response Code	180 Response
RTP Mode in SDP when Call Holding	sendonly
Support Call Waiting of Huawei IPPBX	<input type="checkbox"/> Enable
Accept Orphan 200 Ok	<input type="checkbox"/> Enable
Called Number Preferred	P-Called-Party-ID Header
Caller-ID Preferred	P-Asserted-Identity Header
Check SDP Strictly	<input checked="" type="checkbox"/> Enable
Report SDP Whatever	<input type="checkbox"/> Enable
18x Response Preferred(Without Effective P-Early-Media)	18x Response with SDP
FlashHook Operation Mode	Mode one
Attended Transfer Trigger	Onhook
Multipart Payload Support	<input type="checkbox"/> Enable
Local Extension is Preferred(Tel in)	<input type="checkbox"/> Enable
Ignore ACK	<input type="checkbox"/> Enable
Report Hook State via SIP INFO	<input type="checkbox"/> Enable
PRACK(RFC3262)	<input type="checkbox"/> Enable
PRACK Only for 18x with SDP	<input type="checkbox"/> Enable
Early Media	<input checked="" type="checkbox"/> Enable
Early Answer	<input type="checkbox"/> Enable
Session Timer(RFC4028)	<input type="checkbox"/> Enable
Session-Expires	1800 s
Min-SE	1800 s
Session Refresh Method	INVITE
T1	500 ms
T2	4000 ms
T4	5000 ms
Max Timeout	32000 ms
Heartbeat Interval(1 - 3600)	10 s
Heartbeat Timeout(4 - (64*T1-1))	16 s
Username of OPTION(Heartbeat) for 'SIP Server'	heartbeat
Username of OPTION(Heartbeat) for 'IP Trunk'	heartbeato
Release all call when Heartbeat Timeout	<input type="checkbox"/> Enable
User-Agent Header	
Response code when Fax Reinvite was Rejected	415

Table-Explanation of SIP Parameters

Parameter	Explanation
RFC3407 Support	Whether to enable RFC3407 support. If this parameter is enabled, the device will support RFC3407 which defines the SDP capability of backward compatibility.
Forbid "user=phone"	When disabled, the "user=phone" is not carried in the URI
"From" SIP URI includes "user=phone"	If this parameter is enabled, 'user=phone' will be contained in URI. When calls are routed to PSTN network, the called number will be got from user name. Default value is 'not enable' .
Default Port Display Policy in SIP URL	It supports Hidden, Display and Hide when the host Is Domain.
INVITE with "P-Preferred-Identity" Header (RFC3325)	If this parameter is enabled, "P-Preferred-Identity" header will be added in INVITE message for anonymous call (Support RFC3325).
Value of "Refer To" refers to "Contact"	If this parameter is enabled, 'contract header' needs to be filled in in the 'refer to' field of a SIP message.
Third Party Do Not Send 18x Response	If this parameter is enabled, the third party will not send 18x response during an attended transfer.
REFER Delay	When the call is in blind transfer status, as a call transfer initiator, it only received a 200 OK from remote side and then send REFER.
Send BYE when Recv REFER Response(Unattended)	If this parameter is enabled, the third party will send BYE to release session after receiving REFER during a blind transfer.

Send New REGISTER when Recv 423 Response	If this parameter is enabled, the value of 'expires' header will be automatically updated and REGISTER will be re-sent after receiving of 423 response.
Verify the Contact Header in REGISTER Response	Enabled it, the contact header will be verified, if the verification failed, the registration will be failed.
Cseq Start with 1	If this parameter is enabled, the value of CSeq starts with '1' .
Forbid Invalid m=line in reINVITE	If this parameter is enabled, the device will prevent 'invalid m=line' from being carried in the SDP of re-INVITE.
SIP Message with ID Header	SIP header carries two types of IDs with MAC or SN.
ID Header Separator	ID header separator for MAC or SN.
Call Waiting Response Code	User can choose 180 or 182 as call waiting response code
RTP Mode in SDP when Call Holding	Use 'send only' or 'inactive' as RTP mode during call holding.
Support Call Waiting of Huawei IPPBX	If this parameter is enabled, the device will support call waiting of Huawei IPPBX.
Accept Orphan 200 OK	If this parameter is enabled, the device will support different 'to-tag 200 OK' in an INVITE session.
Called Number Preferred	Choose P-Called-Party-ID header or Request-Line
Caller-ID Preferred	Choose P-Asserted-Identity header or From Header
Check SDP Strictly	Strictly or not for SDP check.
Report SDP whatever	when enabled, even if 200 OK is received, the device will report SDP

18x Response Preferred(Without Effective P-Early-Media)	It supports 18x Response with SDP, Last 18x Response, and Local Ring Tone Only.
Flashhook Operation Mode	Choose Mode one, Mode two or Mode three
Attended Transfer Trigger	Choose 'Onhook' or 'Flashhook +4'
Multipart Payload Support	Support MIME types.
Ignore ACK	If enabled it, When FXS is off-hook, and even though SIP UA does not receive ACK message, the, the device do not resend 200 OK response.
Report Hook State via SIP INFO	If enabled it, whether the FXS is in Off-hook or on-hook status, SIP-INFO will send.
PRACK(RFC3262)	If this parameter is enabled, the device supports reliable transmission of provisional response
PRACK Only for 18x with SDP	If this parameter is enabled, only PRACK will be sent when there' s SDP in 18x response
Early Media	If this parameter is enabled, the device supports the receiving of Early Media.
Early Answer	If this parameter is enabled, the device supports early answer
Answer Update without Offer (for Port Group)	If this parameter is enabled, the system will update answer proactively although no offer is received.
Session Timer (RFC4028)	Whether to enable 'session timer' , default value is 'not enable' .
Session-Expires	The interval for refreshing session; default value is 1800s. The Session-Expires header field conveys the session interval for a SIP session.

Min-SE	The minimum interval for refreshing session; default value is 1800s. The Min-SE header field indicates the minimum value for the session interval.
Session Refresh Method	The method to refresh session; default value is INVITE.
T1	Value of T1 timer in SIP protocol, default is 500ms
T2	Value of T2 timer in SIP protocol, default is 4000ms
T4	Value of T4 timer in SIP protocol, default is 5000ms
Max Timeout	The max timeout of sending or receiving SIP messages, default is 32000ms
Heartbeat Interval	The interval for sending heartbeat message, Default is 10s.
Heartbeat Timeout	The timeout for heartbeat message to be sent, default to 16s
Username of OPTION(Heartbeat) for "SIP Server"	The user ID part of OPTION SIP message in the heartbeat request for SIP server
Username of OPTION(Heartbeat) for "IP TRUNK"	The user ID part of OPTION SIP message in the heartbeat request for IP trunk
Release all call when Heartbeat Timeout	Then the heartbeat timeout expired, all the calls will be released or terminated.
User-Agent Header	Customize the UA header
Response code when Fax Reinvite was Rejected	Customized the SIP response code for Fax rejection.

4.10.6 NAT Parameter

NAT Config

NAT Traversal	<input type="text" value="STUN"/>
Refresh interval	<input type="text" value="60"/> s
STUN Server Address	<input type="text"/>
STUN Server Port	<input type="text" value="3478"/>
Via of Message	<input checked="" type="radio"/> Local Address <input type="radio"/> NAT Address
Contact of Message	<input type="radio"/> Local Address <input checked="" type="radio"/> NAT Address
SDP of Message	<input type="radio"/> Local Address <input checked="" type="radio"/> NAT Address

NAT Traversal (Network Address Translator Traversal) is a computer networking technique of establishing and maintaining Internet protocol connections across gateways that implement network address translation (NAT). NAT breaks the principle of end-to-end connectivity originally envisioned in the design of the Internet.

STUN (Simple Traversal of UDP over NATs) is a lightweight protocol that allows applications to discover the presence and types of NATs and firewalls between them and the public Internet. It also provides the ability for applications to determine the IP addresses allocated to them by the NAT. STUN works with many existing NATs, and does not require any special behavior from them. STUN doesn't support TCP connection and H.323.

Parameter	Explanation
NAT Traversal	The device supports 3 types of NAT traversal methods: STUN, static NAT, dynamic NAT
NAT IP	When static NAT is selected as the NAT traversal method, a static NAT address needs to be configured
Refresh interval	When STUN is selected as the NAT traversal method, the device queries the NAT address at certain intervals
STUN Server Address	Configure IP address of STUN server (it support IP address or domain name)

STUN Server Port	Configure port of STUN server
Via of Message	Via header in SIP messages uses local network address or NAT address
Contact of Message	Contact header in SIP messages uses local network address or NAT address
SDP of Message	SDP in SIP messages uses local network address or NAT address

4.10.7 Speed Dial

Speed dial is a function that is available on telephones which provides an easy method of calling a telephone number by pressing fewer digits on the keypad. The tool enables one to save, organize, and have easy and quick access to regularly dialed numbers.

Speed Dial		
Index	Speed Dial Number	Original Number
---	---	---

Total: 0 Entry

Speed Dial - Add	
Index	<input type="text" value="0"/>
Speed Dial Number	<input type="text"/>
Original Number	<input type="text"/>

4.10.8 Feature Code

Feature	Codes	Use Default	Status
Device Function			
Inquiry LAN IP	*158#	<input checked="" type="checkbox"/>	Enable <input type="button" value="v"/>
Inquiry Phone Number	*114#	<input checked="" type="checkbox"/>	Enable <input type="button" value="v"/>
Inquiry PortGroup Number	*115#	<input checked="" type="checkbox"/>	Enable <input type="button" value="v"/>
Inquiry Registration Status	*168#	<input checked="" type="checkbox"/>	Enable <input type="button" value="v"/>
Remove Login Limit	*154#	<input checked="" type="checkbox"/>	Enable <input type="button" value="v"/>
Setting IP Mode	*150*	<input checked="" type="checkbox"/>	Enable <input type="button" value="v"/>
Configure IP Address	*152*	<input checked="" type="checkbox"/>	Enable <input type="button" value="v"/>
Network Subnet Mask Configure	*153*	<input checked="" type="checkbox"/>	Enable <input type="button" value="v"/>
Network Gateway Configure	*156*	<input checked="" type="checkbox"/>	Enable <input type="button" value="v"/>
Port Voice Up	*170#	<input checked="" type="checkbox"/>	Enable <input type="button" value="v"/>
Port Voice Down	*171#	<input checked="" type="checkbox"/>	Enable <input type="button" value="v"/>
Reset Basic Configuration	*165*	<input checked="" type="checkbox"/>	Enable <input type="button" value="v"/>
Reset Factory Configuration	*166*	<input checked="" type="checkbox"/>	Enable <input type="button" value="v"/>
Restart Device	*111#	<input checked="" type="checkbox"/>	Enable <input type="button" value="v"/>
Call Function			
Call by IP	*47*	<input checked="" type="checkbox"/>	Enable <input type="button" value="v"/>
Call Waiting Activate	*51#	<input checked="" type="checkbox"/>	Enable <input type="button" value="v"/>
Call Waiting Deactivate	*50#	<input checked="" type="checkbox"/>	Enable <input type="button" value="v"/>
Blind Transfer	*87*	<input checked="" type="checkbox"/>	Enable <input type="button" value="v"/>
Call Forward Unconditional Activate	*72*	<input checked="" type="checkbox"/>	Enable <input type="button" value="v"/>
Call Forward Unconditional Deactivate	*73#	<input checked="" type="checkbox"/>	Enable <input type="button" value="v"/>
Call Forward Busy Activate	*90*	<input checked="" type="checkbox"/>	Enable <input type="button" value="v"/>
Call Forward Busy Deactivate	*91#	<input checked="" type="checkbox"/>	Enable <input type="button" value="v"/>
Call Forward No Reply Activate	*92*	<input checked="" type="checkbox"/>	Enable <input type="button" value="v"/>
Call Forward No Reply Deactivate	*93#	<input checked="" type="checkbox"/>	Enable <input type="button" value="v"/>
Do Not Disturb Activate	*78#	<input checked="" type="checkbox"/>	Enable <input type="button" value="v"/>
Do Not Disturb Deactivate	*79#	<input checked="" type="checkbox"/>	Enable <input type="button" value="v"/>
Dial Voicemail	*200#	<input checked="" type="checkbox"/>	Enable <input type="button" value="v"/>
DTMF Function			
Call Holding	*#	<input checked="" type="checkbox"/>	Enable <input type="button" value="v"/>
Call Switch	##	<input checked="" type="checkbox"/>	Enable <input type="button" value="v"/>

Save

Parameter	Explanation
Inquiry LAN IP	Dial*158# to obtain device' s LAN port IP address
Inquiry Phone Number	Dial*114# to obtain port account
Inquiry Port Group Number	Dial *115# to obtain port group number
Inquiry Registration Status	Dial *168# to query the register status of a FXS port
Remove Login Limit	Dial *154# to remove login limit
Setting IP Mode	*150*0#, means pppmodem, *150*1#, means static IP, *150*2#, means obtain IP address by DHCP, *150*3#, means pppoe.
Configure IP Address	*152*+IP, set gateway IP address
Network subnet mask configure	*153*+subnet mask, set gateway subnet mask
Network Gateway Configure	*156*+gateway IP, set gateway
Port Voice Up	Dial *170# to increase the sound volume of a FXS port
Port Voice Down	Dial *171# to decrease the sound volume of a FXS port
Reset Basic Configuration	Dial *165*000000# to restore default username/password and network configuration
Reset Factory Configuration	*166*000000#, reset factory
Restart Device	*111#, restart device
Call by IP	Directly dial the end user IP to call
Call Waiting Activate	*51#, enable call waiting function

Call Waiting Deactivate	*50#, forbid call waiting function
Blind Transfer	If the call transfer to 801, first hook flash and then dial the * 87 * 801#
Call Forward Unconditional Activate	*72*+ phone number#, transfer the call from the phone number
Call Forward Unconditional Deactivate	*73#, forbid call forward unconditional
Call Forward Busy Activate	*90*+ forward busy number#
Call Forward Busy Deactivate	*91#, forbid call forward busy
Call Forward No Reply Activate	*92*+ forward no reply number#
Call Forward No Reply Deactivate	*93#, close this function
Do Not Disturb Activate	*78#, enable DND function
Do Not Disturb Deactivate	*79#, close DND function
Dial Voicemail	*200#, visit voice mail box
Call Holding	During a call, dial*# into call hold. (Recovery the call through hook flash or *#)
Call Switch	Dial *# to release the current call and restore inactive call

4.10.9 System Parameter

System parameters include NTP, daylight saving time, daily reboot time, web parameter, telnet parameter and remote management. NTP (Network Time Protocol) is a computer time synchronization protocol.

Figure-Configure System Parameters

System Config

Hint Language

NTP Enable

Primary NTP Server Address

Primary NTP Server Port

Secondary NTP Server Address

Secondary NTP Server Port

SYN Interval s

Time Zone

Local Time 5/15/2023, 3:11:34 PM

Daylight Saving Time Enable

Log

Summary Enable

System Log Enable

Network Diagnose

The local network fault detection (Please close for network disable ping) Enable

The local network interruption detection Enable

WEB Parameter

WEB Port

SSL Port

Telnet Parameter

Telnet Port

Table-Explanation of System Parameters

Parameter	Explanation
NTP	To enable or disable NTP
Primary NTP server address	The IP address of primary NTP server; default IP address is us.pool.ntp.org.
Primary NTP server port	The service port of primary NTP server; default port is 123.
Secondary NTP server address	The IP address of secondary NTP server; Default IP address is 64.236.96.53
Secondary NTP server port	The service port of secondary NTP server; Default port is 123
SYN Interval	The interval to synchronize the time of the DAG2500-48S/72S/96S. Default value is 3600s.
Time Zone	The time zone of the device; Default configuration is United States central time, Chicago.
Daylight Saving Time	Enable or disable daylight saving time
Daily Reboot	Whether to enable daily reboot
Reboot time	The time to reboot the device daily
WEB Port	The web port of the device; Default port is 80
SSL Port	The SSL port; Default is 443
Telnet port	Listening port of telnet service; Default port is 23

【Note】 After Web port and Telnet port are configured, please restart the device for the configurations to take effect.

4.11 Call & Routing

4.11.1 Wildcard Group

Wildcard Group	
Wildcarded IMPU	Associated IMPU
---	---

4.11.2 Port Group

When two or more FXS ports need to register with a same SIP account, you can group the ports together and then set an account for the group on the **Call & Routing->Port Group** page.

Parameters of port group include registration, primary display name, primary SIP user id, primary authentication ID and password, secondary display name, secondary SIP user id, secondary authentication ID and password, off-hook auto dial, auto dial delay time, port select, etc.

Figure-Add Port Group

Port Group										
Index	IP Profile	Description	Display Name	SIP User ID	Authenticate ID	Offhook Auto-Dial	Port	Port Select	Pick Up on Group	
---	---	---	---	---	---	---	---	---	---	---

Total: 0 Entry ▼

Port Group Add

Index	<input type="text" value="95"/>
Registration	<input checked="" type="checkbox"/> Enable
IP Profile	<input type="text" value="0 <default>"/>
Description	<input type="text"/>
Display Name	<input type="text"/>
SIP User ID	<input type="text"/>
Authenticate ID	<input type="text"/>
Authenticate Password	<input type="text"/>
Offhook Auto-Dial	<input type="text"/>
Auto-Dial Delay Time	<input type="text"/> s
Port Select	<input type="text" value="Cyclic Ascending"/>
Pick Up on Group	<input type="text" value="*#"/>
Call Answer Timeout	<input type="text" value="15"/>
Select Port Count	<input type="text" value="Cyclic Select"/>
Port	<input type="button" value="Select Port for this Group"/>

Table-Parameter Explanation of Port Group

Parameter	Explanation
Index	The NO. of the port group; It uniquely identifies a route.
Registration	Registration
IP Profile	IP Profile
Description	The description of the port group; it is used to identify the port group.
Display Name	<p>Display name of the port group, which will be used in SIP message, for example:</p> <pre>INVITE sip:bob@biloxi.com SIP/2.0</pre> <p>Via:</p> <pre>SIP/2.0/UDPpc33.atlanta.com;branch=z9hG4bK776asd</pre> <p>hds</p> <p>Max-Forwards: 70</p> <p>To: Bob <sip:bob@biloxi.com></p> <p>From: Alice <sip:alice@atlanta.com>;tag=1928301774</p> <p>Here Bob and Alice are the display name</p>
SIP User ID	User ID of this SIP account, which is provided by VoIP service provider (ITSP). It is usually in the form of digit similar to phone number or an actual phone number.
Authenticate ID	SIP service subscriber' s ID for authentication; it can be identical to or different from SIP User ID.
Authenticate Password	SIP service subscriber' s password for authentication

Offhook Auto-Dial	An extension or phone number is pre-assigned here so that the number is automatically dialed as soon as user picks up the phone
Auto-dial Delay time	How long auto-dialing will be delayed
Port Select	<p>It specifies the policy for selecting a port for ringing in the port group</p> <ul style="list-style-type: none"> • Ascending: the device always selects a port from the minimum number. • Cyclic ascending: the device always selects a port from a number next to the number selected last time. If the maximum number was selected last time, the next selected number is the minimum number. The sequence moves in cycles like this. • Descending: the device always selects a port from the maximum number. • Cyclic descending: the device always selects a port from a number next to the number selected last time. If the minimum number was selected last time, the next selected number is the maximum number. The sequence moves in cycles like this. • Group ring: all ports ring at the same time
Pickup UP on group	When one port rings, user can dial '*#' to pick up the call from other ports under the same port group.
Call Answer Timeout	Time for Ring group is expired, select next port for ring. Default time is 15s and rang from 10-120s.
Select Port Count	Support Port Count: Cyclic Select and Only Once.
Port	Select ports for this port group

4.11.3 IP Trunk

A peer-to-peer VoIP call occurs when two VoIP phones communicate directly over IP network without IP PBXs between them. IP trunk helps establish peer-to-peer call between gateway and VoIP phones. IP trunk will be used in routing configuration.

Figure-Configure IP Trunk

The screenshot displays the IP Trunk configuration interface. At the top, there is a table titled 'IP Trunk' with the following columns: Index, Description, Remote Address, Remote Port, and Heartbeat. The table is currently empty. Below the table, there are three buttons: 'Add', 'Modify', and 'Delete'. To the right of the table, it says 'Total: 0 Entry' with a dropdown arrow. Below the buttons is the 'IP Trunk Add' form. This form contains the following fields: 'Index' (a dropdown menu showing '127'), 'Description' (a text input field), 'Remote Address' (a text input field), 'Remote Port' (a text input field), and 'Heartbeat' (a checkbox labeled 'Enable').

Table-Explanation of IP Trunk Parameters

Parameter	Explanation
Index	The No. of the IP trunk; range is from 0 to 127.
Description	The description of the IP trunk; it is used to identify the IP trunk.
Remote Address	IP address or domain name of the peer device
Remote Port	SIP port of the peer device
Heartbeat	Whether to enable the 'Heartbeat' function for the IP trunk. Default value is 'not enable'. If heartbeat is enabled, the device will send "OPTION" to the peer device.

4.11.4 Routing Parameter

Routing parameter determines a call routed before or after manipulation.

Figure-Configure Routing Parameter

The screenshot shows a configuration window titled "Routing Parameter". Inside, there are two rows of configuration options. The first row is "Calls from IP" with a dropdown menu set to "Routing before Manipulation". The second row is "Calls from Analog Line" with a dropdown menu also set to "Routing before Manipulation". Below the configuration area is a "Save" button.

Table-Explanation of Routing Parameters

Parameter	Explanation
Calls from IP	Choose calls from IP network are routed before manipulation or after manipulation.
Calls from Analog Line	Choose calls from analog lines are routed before manipulation or after manipulation.

4.11.5 IP ->Tel Routing

Calls from IP network can be routed to FXS port or port group of the device through IP->Tel routing.

Figure-Add IP->Tel Route

IP->Tel Routing

Index	Description	Calls from	Caller Prefix	Called Prefix	Calls to
---	---	---	---	---	---

Total: 0 Entry ▼

Add
Modify
Delete
BatchAdd
FileImport

IP->Tel Routing Add

Index

Description

Calls from
 IP Trunk
 SIP Server

Caller Prefix

Called Prefix

Calls to
 Port
 Port 0
 Port Group

Save
Reset
Cancel

Table-Parameter Explanation of IP->Tel Routes

Parameter	Explanation
Index	Index of the IP Tel routing; range is from 0 to127; 0 is the highest priority.
Description	Description of the IP Tel routing; it is used to identify the IP Tel routing.
Calls from	Choose calls from IP trunk or SIP server; 'any' means any IP addresses.
Caller Prefix	The prefix of the caller number, which helps match routing exactly. Its length is less than or equal to the caller number. For example, if caller number is 2001, the caller prefix can be 200 or 2. 'Any' means the prefix matches any caller number.

Callee Prefix	The prefix of the called number, which helps match routing exactly. Its length is less than or equal to the called number. If the called number is 008675526456659, the called prefix can be 0086755 or 00. "any" means the prefix matches any called number
Calls to	Which port or port group to which calls are routed.

4.11.6 Tel->IP/Tel Routing

Calls from the FXS port or port group can be routed to IP trunk or ports of SIP server/other device through Tel->IP/Tel routing.

Figure-Add Tel->IP/Tel Route

Tel->IP/Tel Routing

Index	Description	Calls from	Caller Prefix	Called Prefix	Calls to
---	---	---	---	---	---

Total: 0 Entry ▼

Tel->IP/Tel Routing Add

Index

Description

Calls from

Port Slot 0 ▼

Port 0 ▼

Port Group

Caller Prefix

Called Prefix

Calls to

Port Slot 0 ▼

Port 0 ▼

Port Group

IP Trunk

SIP Server

Table-Explanation of Tel->IP/Tel Route

Parameter	Explanation
Index	The index of this Tel IP/Tel routing; range is from 0 to 127. Each index cannot be used repeatedly. Routing priority: 0 is the highest priority.
Description	The description of this Tel IP/Tel routing; it is used to identify the routing.
Calls From	Choose calls are from a port or a port group
Caller Prefix	The prefix of the caller number, which helps match routing exactly. Its length is less than or equal to the caller number. For example, if caller number is 2001, the caller prefix can be 200 or 2. 'any' means the prefix matches any caller number.
Called Prefix	The prefix of the called number, which helps match routing exactly. Its length is less than or equal to the called number. If the called number is 008675526456659, the called prefix can be 0086755 or 00. "any" means the prefix matches any called number.
Calls to	Choose calls are routed to a port, port group, IP trunk or SIP server

4.12 Manipulation

Number manipulation refers to the change of a called number or a caller number during calling process when the called number or the caller number matches the existing rules.

4.12.1 IP->Tel Called

On the **IP->Tel Called submenu** page, you can set rules for manipulating the called number of IP Tel calls.

Figure-Add IP->Tel Called Number Manipulation

Index	Description	Calls from	Caller Prefix	Called Prefix	Calls to	Stripped Digits from Left	Stripped Digits from Right	Prefix to Add	Suffix to Add	Number of Digits to Leave from Right
---	---	---	---	---	---	---	---	---	---	---

Total: 0 Entry

IP->Tel Called Add

Index:

Description:

Calls from: IP Trunk SIP Server

Caller Prefix:

Called Prefix:

Calls to: Port Port Group

Stripped Digits from Left:

Stripped Digits from Right:

Prefix to Add:

Suffix to Add:

Number of Digits to Leave from Right:

Note:"1. 'any' in 'Called Prefix' or 'Caller Prefix' means wildcard string."
 "2. 'Calls to' can config when select the mode 'Route before manipulation'."

Table-Explanation of Parameters for IP->Tel Called Number Manipulation

Parameter	Explanation
Index	The index of this manipulation; range is from 0 to 127. Each index cannot be used repeatedly. 0 is the highest priority
Description	Description of this manipulation; it is used to identify this manipulation.
Calls From	Determine the calls come from IP trunk or SIP server

Caller Prefix	Set a prefix for caller number. The prefix' s length is less than or equal to that of the caller number, which helps to match the caller number of this call. If caller number is 2001, the caller prefix can be 200 or 2. "any" means match any caller number.
Called Prefix	Set a prefix for called number. The prefix' s length is less than or equal to called number, which helps to match the called number. If called number is 008675526456659, the called prefix can be 0086755 or 00. "any" means match any called number.
Calls to	Determine the call is routed to a port or a port group.
Stripped Digits from Left	The number of digits which are lessened from the left of the called number
Stripped Digits from Right	The number of digits which are lessened from the right of the called number
Prefix to Add	The prefix added to the called number after its digits are lessened.
Suffix to Add	The suffix added to the called number after its digits are lessened.
Number of Digits to Leave from Right	For an incoming call, reserved digits from callee number, starting count numbers from right of callee number.

4.12.2 Tel->IP/Tel Caller

On the **Tel->IP/Tel Caller** page, you can set rules for manipulating the caller number of Tel->IP/Tel calls.

Figure-Add Tel->IP/Tel Caller Number Manipulation

Tel->IP/Tel Caller										
Index	Description	Calls from	Caller Prefix	Called Prefix	Calls to	Stripped Digits from Left	Stripped Digits from Right	Prefix to Add	Suffix to Add	Number of Digits to Leave from Right
---	---	---	---	---	---	---	---	---	---	---

Total: 0 Entry ▼

Tel->IP/Tel Caller Add

Index:

Description:

Calls from: Port

 Port Group

Caller Prefix:

Called Prefix:

Calls to: Port

 Port Group
 IP Trunk
 SIP Server

Stripped Digits from Left:

Stripped Digits from Right:

Prefix to Add:

Suffix to Add:

Number of Digits to Leave from Right:

Note:"1. 'any' in 'Called Prefix' or 'Caller Prefix' means wildcard string."
 "2. 'Calls to' can config when select the mode 'Route before manipulation'."

Table-Explanation of Parameters for Tel->IP/Tel Caller Number Manipulation

Parameter	Explanation
Index	The index of this manipulation; range is from 0 to 127. Each index cannot be used repeatedly. 0 is the highest priority

Description	Description of this manipulation; it is used to identify this manipulation.
Calls From	Determine the calls come from a port or a port group.
Caller Prefix	Set a prefix for caller number. The prefix' s length is less than or equal to that of the caller number, which helps to match the caller number of this call. If caller number is 2001, the caller prefix can be 200 or 2. 'any' means match any caller number.
Called Prefix	Set a prefix for called number. The prefix' s length is less than or equal to called number, which helps to match the called number. If called number is 008675526456659, the called prefix can be 0086755 or 00. 'any' means match any called number.
Calls to	Determine the call is routed to a port, a port group, an IP trunk or a SIP server.
Stripped Digits from Left	The number of digits which are lessened from the left of the caller number
Stripped Digits from Right	The number of digits which are lessened from the right of the caller number
Prefix to Add	The prefix added to the caller number after its digits are lessened.
Suffix to Add	The suffix added to the caller number after its digits are lessened.
Number of Digits to Leave from Right	For an incoming call, reserved digits from callee number, starting count numbers from right of callee number.

4.12.3 Tel->IP/Tel Called

On the **Tel->IP/Tel Called** page, you can set rules for manipulating the called number of Tel IP/Tel calls.

Figure Add Tel->IP/Tel Called Number Manipulation

Tel->IP/Tel Called										
Index	Description	Calls from	Caller Prefix	Called Prefix	Calls to	Stripped Digits from Left	Stripped Digits from Right	Prefix to Suffix to Add	Number of Digits to Leave from Right	

Total: 0 Entry

Tel->IP/Tel Called Add

Index	<input type="text" value="127"/>
Description	<input type="text"/>
Calls from	<input checked="" type="radio"/> Port <input type="text" value="Slot 0"/> <input type="radio"/> Port Group <input type="text" value="Port 0"/>
Caller Prefix	<input type="text"/>
Called Prefix	<input type="text"/>
Calls to	<input type="radio"/> Port <input type="text" value="Slot 0"/> <input type="radio"/> Port Group <input type="text" value="Port 0"/> <input type="radio"/> IP Trunk <input type="text" value="Any"/> <input checked="" type="radio"/> SIP Server
Stripped Digits from Left	<input type="text"/>
Stripped Digits from Right	<input type="text"/>
Prefix to Add	<input type="text"/>
Suffix to Add	<input type="text"/>
Number of Digits to Leave from Right	<input type="text"/>

Note: "1. 'any' in 'Called Prefix' or 'Caller Prefix' means wildcard string."
 "2. 'Calls to' can config when select the mode 'Route before manipulation'."

Table-Explanation of Parameters for Tel->IP/Tel Called Number Manipulation

Parameter	Explanation
Index	The index of this manipulation; range is from 0 to 127. Each index cannot be used repeatedly. 0 is the highest priority
Description	Description of this manipulation; it is used to identify this manipulation.
Calls From	Determine the calls come from a port or a port group.
Caller Prefix	Set a prefix for caller number. The prefix' s length is less than or equal to that of the caller number, which helps to match the caller number of this call. If caller number is 2001, the caller prefix can be 200 or 2. 'any' means match any caller number.
Called Prefix	Set a prefix for called number. The prefix' s length is less than or equal to called number, which helps to match the called number. If called number is 008675526456659, the called prefix can be 0086755 or 00. 'any' means match any called number.
Calls to	Determine the call is routed to a port, a port group, an IP trunk or a SIP server.
Stripped Digits from Left	The number of digits which are lessened from the left of the called number
Stripped Digits from Right	The number of digits which are lessened from the right of the called number.
Prefix to Add	The prefix added to the called number after its digits are lessened.
Suffix to Add	The suffix added to the called number after its digits are lessened.

Number of Digits to Leave from Right	For an incoming call, reserved digits from callee number, starting count numbers from right of callee number.
---	---

4.13 Management

4.13.1 TR069

TR069 is short for Technical Report 069, which provides a commonly-used framework and protocol for next-generation network devices. As an application-level protocol on top of IP TR069 has no limitation to access ways of network devices.

Under the network management model of TR069, ACS (Auto-Configuration Server) works as a management server, responsible for managing CPEs (Custom Premise Equipment).

ACS URL (auto-configuration server URL address) is provided by service provider. The ACS URL generally starts with http:// or https:// Username and password are used for ACS authentication.

Figure-Configure TR069 Parameter

TR069 Parameter

TR069 Enable

ACS Configuration

ACS URL

User Name

Password

Periodic Inform Enable

Periodic Inform Interval s

Connect Request

User Name

Password

Port

Table-Explanation of TR069 Parameters

Parameter	Explanation
TR069	Choose whether to enable TR069; it is 'not enable' by default.
ACS URL	The IP address or domain name of ACS, which is provided by service provider.
Username(ACS)	Username of ACS, which is provided by service provider.
Password(ACS)	Password of ACS, which is provided by service provider.
Periodic Inform	Choose whether to enable 'Periodic Inform' ; if it is enabled, ACS will connect to CPE every 30 seconds (if the interval is set as 30 seconds).

Periodic Inform Interval	The interval set for periodic connection between ACS and CPE.
Username (CPE)	Username of CPE
Password (CPE)	Password of CPE
Port	The port to connect CPE and ACS

4.13.2 SNMP

SNMP (Simple Network Management Protocol) is an Internet-standard protocol for collecting and organizing information about managed devices on IP networks and for modifying that information to change device behavior. Devices that typically support SNMP include routers, switches, servers, workstations, printers, modem racks and more.

SNMP is widely used in network management for network monitoring. SNMP exposes management data in the form of variables on the managed systems organized in a management information base which describe the system status and configuration. These variables can then be remotely queried (and, in some circumstances, manipulated) by managing applications.

Three significant versions of SNMP have been developed. SNMPv1 is the original version of the protocol. More recent versions, SNMPv2c and SNMPv3, feature improvements in performance, flexibility and security.

Figure-Configure SNMP Parameters

SNMP Parameter

Snm Enable

Snm Version v1 v

Community Configuration

	Community	Source
1	<input style="width: 95%;" type="text"/>	<input style="width: 95%;" type="text"/>
2	<input style="width: 95%;" type="text"/>	<input style="width: 95%;" type="text"/>
3	<input style="width: 95%;" type="text"/>	<input style="width: 95%;" type="text"/>

Note: Value of Source is default or IP Address(eg:192.168.1.1)!

Group Configuration

	Group	Community
1	<input style="width: 95%;" type="text"/>	v
2	<input style="width: 95%;" type="text"/>	v
3	<input style="width: 95%;" type="text"/>	v

View Configuration

	ViewName	ViewType	ViewSubtree	ViewMask
1	<input style="width: 95%;" type="text"/>	v	<input style="width: 95%;" type="text"/>	<input style="width: 95%;" type="text"/>
2	<input style="width: 95%;" type="text"/>	v	<input style="width: 95%;" type="text"/>	<input style="width: 95%;" type="text"/>
3	<input style="width: 95%;" type="text"/>	v	<input style="width: 95%;" type="text"/>	<input style="width: 95%;" type="text"/>

Note: Value style of ViewSubtree is x.x.x.x.x(multi-nodes) or .x(one node).

Access Configuration

	Group	Read	Write	Notify
1	v	v	v	v
2	v	v	v	v
3	v	v	v	v

Note: The value of Read/Write/Notify references to ViewName in View Configuration.Access Configuration is base on Group Configuration and View Configuration.

Trap Configuration

	Trap Type	Trap IP	Trap Port	Trap Community
1	v	<input style="width: 95%;" type="text"/>	0 <input style="width: 95%;" type="text"/>	<input style="width: 95%;" type="text"/>

Save

Table-Explanation of SNMP Parameters

Parameter	Explanation
SNMP	The device supports three versions of SNMP, namely V1, V2C and V3.

<p>Community Configuration</p>	<p>Community configuration exists in V1 and V2C.</p> <p>Community: fill in a community name used to read through SNMP protocol; it is a character string.</p> <p>Source: The IP address of SNMP server.</p> <p>SNMP server cannot identify the packets sent from the gateway unless the community configured in the gateway matches with the community configured in SNMP server.</p>
<p>Group Configuration</p>	<p>Group configuration exists in V1 and V2C and V3.</p> <p>Group: fill in a group name which is used to identify the group; it's a character string.</p> <p>Community: fill in a community which means this community has joined in the group.</p> <p>In the following, access permission of read, write and notify is configured for each group.</p>
<p>View Configuration</p>	<p>View configuration exists in V1, V2C and V3.</p> <p>ViewName: fill in a view name which is used to identify this view.</p> <p>ViewType: choose 'Included' or 'Excluded' . 'Included' means the view includes the OID of the corresponding ViewSubtree, while 'Excluded' means the OID of the corresponding ViewSubtree is excluded from this view.</p> <p>ViewSubtree: fill in the OID of the view subtree.</p> <p>ViewMask: it is used to withdraw a row of a table, such as an Ethernet port.</p>

Access Configuration	<p>Access configuration exists in V1, V2C and V3, under which permission of read, write or notify is configured for a community group.</p> <p>Group: choose a group name that has been configured.</p> <p>Read: Choose a 'read' view for the group.</p> <p>Write: Choose a 'write' view for the group.</p> <p>Notify: Choose a 'notify' view for the group.</p>
Trap Configuration	<p>Trap configuration exists in V1, V2C and V3, which is aimed to send trap alarm.</p> <p>Trap Type: Choose V1, V2C and Inform.</p> <p>Trap IP: the IP address of the destination SNMP server where trap alarm is sent.</p> <p>Trap Port: the port of the destination SNMP server, which will receive trap alarm.</p> <p>Trap Community: the community configured in the destination SNMP server.</p>
User Configuration	<p>User configuration exists in V3. When V3 transmits SNMP packets in an encryption way, this item needs to be configured.</p> <p>User: fill in a user name used to authenticate.</p> <p>AuthType: choose MD5 or SHA as authentication type.</p> <p>AuthPassword: the password used to authenticate.</p> <p>Privacy Type: Choose DES, AES or AES 128 as encryption type.</p> <p>Privacy Password: the encryption password.</p>

4.13.3 Syslog

Syslog is a standard for message logging. It allows separation of the software that generates messages, the system that stores messages, and the software

that reports and analyzes messages. It also provides a means to notify administrators of problems or performance.

Syslog levels include: EMERG, ALERT, CRIT, ERROR, WARNING, NOTICE, INFO and DEBUG.

Figure-Configure Syslog Parameters

Section	Log Type	Enabled
Local Syslog	Local Syslog	<input type="checkbox"/>
	Server Address	<input type="text"/>
	Server Port	<input type="text" value="514"/>
	Syslog Level	<input type="text"/>
	CDR	<input checked="" type="checkbox"/>
	Signal Log	<input type="checkbox"/>
	Media Log	<input type="checkbox"/>
	System Log	<input type="checkbox"/>
Server Syslog	Server Syslog	<input type="checkbox"/>
	Server Address	<input type="text"/>
	Server Port	<input type="text" value="514"/>
	Syslog Level	<input type="text"/>
	Signal Log	<input type="checkbox"/>
	Media Log	<input type="checkbox"/>
	System Log	<input type="checkbox"/>
	Management Log	<input type="checkbox"/>

When the device registers to Cloud server, local syslog will be changed to non-configurable and all logs will be stored on the Cloud server.

4.13.4 Provision

Provision is used to make the device automatically upgrade with the latest firmware stored on an http server, a ftp server or a tftp server. Please refer to the Instruction for Using Provision.

Figure-Provision

The screenshot shows a web interface titled "Provision" with a "Basic Configuration" section. The fields are as follows:

- URL**: A text input field.
- Check server certificate when using HTTPS**: A checkbox labeled "Enable".
- Check Interval**: A text input field with a unit "s" at the end.
- Account**: A text input field.
- Password**: A text input field.
- Proxy Domain**: A text input field.
- Proxy Port**: A text input field.
- Proxy Account**: A text input field.
- Proxy Password**: A text input field.

Table-Explanation of Provision Parameters

Parameter	Explanation
URL	URL of provisioning server, support HTTP, TFTP, FTP
Check server certificate when using HTTPS	Check server certificate when using HTTPS
Check Interval	The interval to check whether there is new firmware version on the provisioning server
Account	Account for logging in provisioning server
Password	Password for logging in provisioning server
Proxy Domain	Proxy Domain
Proxy Port	Proxy Port
Proxy Account	Proxy Account
Proxy Password	Proxy Password

4.13.5 Cloud server

You can register the device to cloud server, and then the device can be managed by the cloud server.

Figure-Configure Cloud Server

The screenshot shows a configuration window titled "Cloud Server". It contains three text input fields labeled "Server Address", "Port", and "Domain". Below these fields is a "Save" button.

Table-Explanation of Parameters for Cloud Server

Parameter	Explanation
Server Address	The IP address of the cloud server
Port	The listening port of the cloud server
Domain	The domain name of the cloud server

4.13.6 User Manage

On the **Management User Manage** page, the administrator of the device can classify users in different groups, and set login username and password for each user.

Figure-Modify Username and Password

The screenshot shows a table titled "User" with the following data:

	User Name	Group	Enabled
<input type="checkbox"/>	admin	Admin	enable

Below the table are three buttons: "Add", "Modify", and "Delete".

Add a User

User Name

Group

Enabled

Password

Confirm Password

Table-Explanation of Parameters for adding a User

Parameter	Explanation
Username	Username
Group	Support User and Guest
Enabled	Enabled
Password	Password
Confirm Password	Confirm password

4.13.7 Remote Server

In case that you need remote technical support, technical support engineers can connect your device with a service server on the **Management Remote Server** page, so as to better help you to solve problems.

Figure-Configure Remote Server

Remote Server

Server URL/IP

Server Port

Parameter	Explanation
Server URL/IP	Server URL/IP
Server Port	Server Port

4.13.8 Record Parameter

Record Parameter

RCD Enable

Server Address

Rcd Port

Rcd Period Select

Rcd Directly To Server Enable

Parameter	Explanation
RCD	Enable or disable the recording function
Server Address	Set recording server address, and support IP address or domain name
Rcd Port	Set the recording server port, the default is 2999
Rcd Period Select	Support setting 3 recording time periods, the recording function will be enabled within the time period.
Rcd Directly To Server	Recording can be sent directly to the server in a NAT environment.

4.13.9 Radius Parameter

Radius Config

Radius Enable
Local Port
Device Behavior Upon RADIUS Timeout

Server IP
Server Auth Port
Server Key

Note: The device must restart to take effect.

Parameter	Explanation
Radius	Enable or disable Radius
Local Port	Port of the local Radius client
Device Behavior Upon RADIUS Timeout	Support Verify Access Locally and Deny Access.
Server IP	IP address of the Radius server
Server Auth Port	Authentication port of Radius server
Server Key	The authentication key for the Radius server

4.13.10 Action URL

Action URL is a means of allowing VoIP platform/VoIP server to learn about the statuses of the device. This is realized by GET request over the HTTP protocol. During the transmission of status, some data (such as device ID, mac address, called/caller number, IP address) carried in GET request can also be reported to VoIP platform/VoIP server.

The data that can be carried in GET request, please refer to the notes on the **Management Action URL** page.

Figure-Configure Action URL

Event	Action URI
Startup	<input type="text"/>
Offhook	<input type="text"/>
Onhook	<input type="text"/>
Incoming Call	<input type="text"/>
Outgoing Call	<input type="text"/>
Call Build	<input type="text"/>
Call Terminate	<input type="text"/>
Register Status	<input type="text"/>
Heartbeat	<input type="text"/>
Heartbeat Interval	<input type="text" value="10"/> s

Event: Statuses of device, which will be reported to VoIP platform/VoIP server.

Action URL: for example, [http://host:port/file.php?macaddr=\\$mac](http://host:port/file.php?macaddr=$mac), among which 'host' means the HTTP server's IP address or domain name, 'port' means the http server's listening port, 'file.php' means the script that will process this request, and '\$mac' means the parameter carried in the request when this request is sent out.

Heartbeat: heartbeat packets are sent to URL by the device, used to examine the connection between the device and HTTP/HTTP server.

4.13.11 SIP PNP

Gateway can restore or upgrade the system firmware by SIP PNP method. The process of SIP PNP is follow:

- Gateway reproducibly send SIP subscribe requests to broadcast.
- Once, the gateway received Notify message from a server and get a URL.
- Gateway sends the request to the URL, then start provision for restore or upgrade

SIP PNP

PNP Enable	<input checked="" type="checkbox"/>
Server Address	<input style="width: 80%;" type="text" value="224.0.1.75"/>
Server Port	<input style="width: 80%;" type="text" value="5060"/>
Update Interval	<input style="width: 80%;" type="text" value="3600"/> s

Parameter	Explanation
PNP Enable	Enable or disable PNP
Server Address	The IP address of the SIP PNP server, and the default is 224.0.1.75
Server Port	Port of the SIP PNP server, and the default is 5060
Update Interval	Send subscription messages periodically, and the default is 3600s

4.13.12 NMS Configuration

Network Management System (NMS) is an easy-to-use and centralized tool to manage, monitor and troubleshoot of all the devices including Gateways, IP Phones, IP PBXs, Session Border Controllers, and SIP Intercoms. With device management, alarm system, service management, log management, report management and statistical analysis, it allows enterprises and service providers to centrally and easily deploy and manage a large network of devices.

NMS Configuration

NMS Enable	<input checked="" type="checkbox"/> Enable
NMS Address	<input style="width: 80%;" type="text"/>
NMS Port	<input style="width: 80%;" type="text" value="0"/>

Parameter	Explanation
NMS Enable	Enable NMS
NMS Address	IP address or domain address of the NMS server
NMS Port	Port of the NMS server, the default is 0

4.14 Security

4.14.1 WEB ACL

ACL (Access Control List) for Web is used to configure IP addresses that are allowed to access the Web Interface of the device. The IP address list can't be null once ACL is enabled.

Figure-Add IP Address to Web ACL

Parameter	Explanation
ACL for WEB	ACL for WEB
Del	Delete IP address

Add	Add IP address
------------	----------------

4.14.2 Telnet ACL

ACL (Access Control List) for Telnet is used to configure IP addresses that are allowed to access the Telnet Interface of the device. The IP address list can't be null once ACL is enabled.

Figure-Add IP Address to Telnet ACL

Parameter	Explanation
ACL for TEL	ACL for Telnet
Del	Delete IP address
Add	Add IP address

4.14.3 Passwords

You can configure or modify the username and password for logging in the Web interface and the Telnet interface of the device on this page.

Note: Both the username and password of Web and Telnet are 'admin' and 'admin' by default. It is advised to modify username and password for security consideration.

Figure-Modify Username and Password

The screenshot displays a web interface titled "Password Modification" with a blue header. It is divided into two sections: "Web Config" and "Telnet Config". Each section contains five input fields. In the "Web Config" section, the "Old Web Username" field contains the text "admin". The "Telnet Config" section also has its "Old Telnet Username" field containing "admin". All other fields are empty. Below the form is a "Save" button.

4.14.4 Encrypt

When the device is registered to a VOS softswitch, you can encrypt SIP and RTP for the VOS softswitch.

Figure-Encrypt SIP and RTP

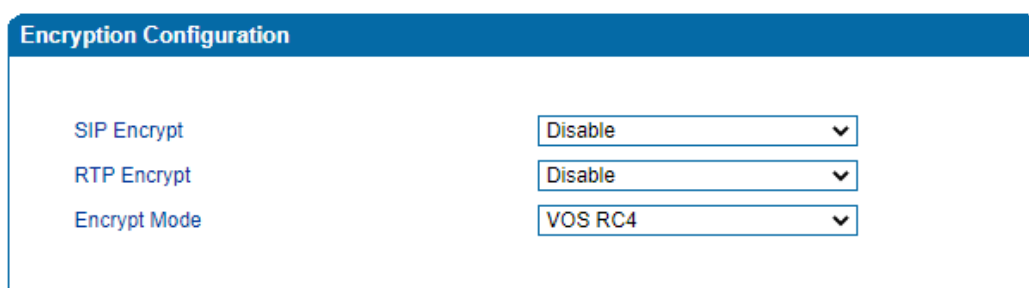

Encryption Configuration	
SIP Encrypt	Disable
RTP Encrypt	Disable
Encrypt Mode	VOS RC4

Note:1. Use the account authentication password can be encrypted SIP
2. Enable SIP encryption will disable anonymous call and heartbeat.

Save

Note: If SIP encryption is enabled, heartbeat and anonymous calls should be disabled.

4.15 Tools

4.15.1 Firmware Upload

On the **Tools Firmware Upload** page, you can upload a new firmware version from a local folder.

Figure-Upload Firmware



Firmware Upload	
File Type	Package
Upload upgrade file from your computer to the device.	
Package	选择文件 未选择任何文件
Upload	

Note:1. The upload process will last about 60s.
2. Do not shut down when the device is loading.
3. If loaded successful, Pls restart device to take effect.

Steps of Firmware Uploading:

Step 1. Check the current firmware version on the **Status & Statistics System Information** page.

Step 2. Prepare firmware package.

Step 3. Upload firmware, select the package from a specific folder on the computer and click the **Upload** button.

Step 4. Keep waiting until it prompts 'Software loaded successfully!'

Step 5. Reboot the device on the **Tools Device Restart** page.

4.15.2 Data Backup

On the **Tools Data Backup** page, you can download and backup configuration data, device status and summary messages on local computer.

Figure-Backup Data

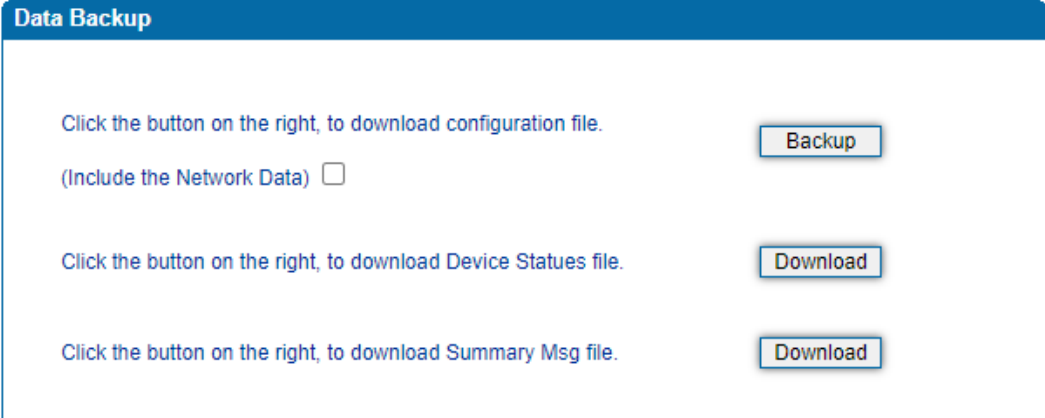

The screenshot shows a web interface titled "Data Backup". It contains three rows of text and buttons:

- Row 1: "Click the button on the right, to download configuration file." followed by a "Backup" button. Below this is a checkbox labeled "(Include the Network Data)".
- Row 2: "Click the button on the right, to download Device Statuses file." followed by a "Download" button.
- Row 3: "Click the button on the right, to download Summary Msg file." followed by a "Download" button.

4.15.3 Data Restore

On the **Tools Data Restore** page, you can restore configuration data through uploading a data file from local computer. The restored configurations will take effect after the device is restarted.

Figure-Restore Data



- Note:
1. The configuration file contains the password can contain only digits, letters and half-width characters(exception: ', ', '\')
 2. If restore successful, Pls restart device to take effect.

4.15.4 Outward Test

Outward test enables you to diagnose the physical function of FXS port which follow the GR909 standard. To start outward test, select the FXS ports to be tested and click 'Start'. The testing may take a few minutes.

Figure-Execute Outward Test

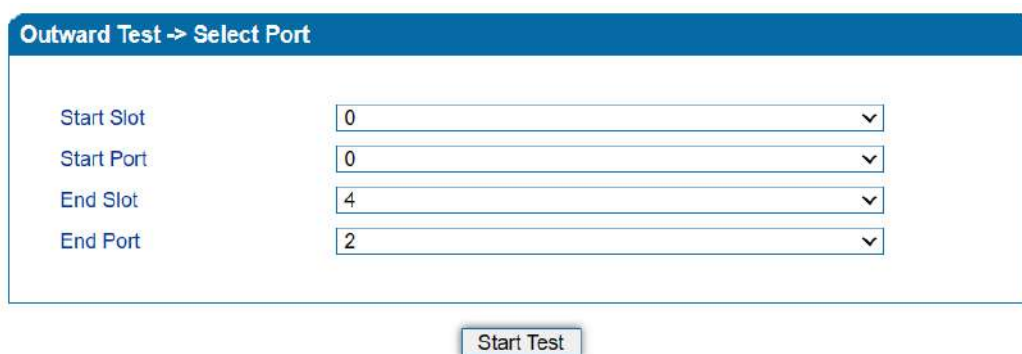

Test Results:

OK: the physical function of the tested FXS ports is working well;

FAIL: There's something wrong with the physical function of the tested FXS ports.

4.15.5 Ping Test

Ping is used to examine whether a network works as normal through sending test packets and calculating response time.

Instructions for using Ping:

1. Enter the IP address or domain name of a network, a website or a device in the input box of Ping, and then click **Start**.
2. If related messages are received, it means the network connection works as normal; otherwise, the network connection is down.

Figure-Execute Ping Test

The image shows a web-based interface for a Ping Test. It consists of two main sections: 'Ping Test' and 'Information'. The 'Ping Test' section has a blue header and contains three input fields: 'Destination' (empty), 'Number of Ping(1-100)' (4), and 'Packet Size(56-1024 bytes)' (56). Below these fields are two buttons: 'Start' and 'Stop'. The 'Information' section has a blue header and is currently empty.

4.15.6 Tracert Test

Tracert is short for traceroute, used to track a route from one IP address to another.

Instruction for using Traceroute:

- 3.2.1.1.1.11 Enter the IP address or domain name of a destination device in the input box of Traceroute, and then click **Start**.

Figure-Execute Tracert Test

The image shows a software interface for executing a Tracert test. It consists of two main sections: 'Tracert Test' and 'Information'. The 'Tracert Test' section has a blue header and contains two input fields: 'Destination' and 'Max Hops(1-255)'. The 'Max Hops' field contains the value '30'. Below these fields are two buttons labeled 'Start' and 'Stop'. The 'Information' section has a blue header and contains a large, empty table with three columns and one row, intended for displaying the results of the Tracert test.

Destination: the IP address or domain name of a destination device that needs to be tracked.

Max Hops: the maximum hops for searching the above IP address or domain name. For example, if 'max hops' is set as 30, and the configured IP address or domain name cannot be reached within 30 hops, it's thought that the IP address or domain name cannot be searched.

3.2.1.1.1.12 View the route information from the returned message.

4.15.7 Network Capture

Network capture is an important diagnostics tool for maintenance. It is used to capture data packages of the available network ports.

PCM Capture:

PCM capture helps to analysis voice stream between analog phone and DSP chipset.

Figure-Capture PCM Packages

The screenshot shows a 'Network Capture' window with the following settings:

- Type: Network package, PCM, Syslog, DSP
- Select Type: According slot, According port
- DTU: DTU0
- Slot: Slot 1
- Port: Port 6

Note:

- 1.If you want get the PCM packets, please select a port.
- 2.If you want get the syslog packets, please make sure syslog is enabled.

Start Stop

- ◆ Click "Start" to enable PCM capture
- ◆ Dialing out through the device, start talking a short while then hang up the call.
- ◆ Click 'Stop' to disable network capture
- ◆ Save the file to local computer

The captured package is named 'capture(x).pcap' . x is the serial number of the capturing and will be added 1 in next time.

Syslog Capture:

Syslog capture is another way to obtain syslog which is the same as remote syslog server and file log. The captured file is saved as pcap format so that it can be opened in some of capturing software like Wireshark, Ethereal software etc.

Figure-Capture Syslog Packages

The screenshot shows a 'Network Capture' window with the following settings:

- Type: Network package, PCM, Syslog, DSP
- DTU: DTU0

Note:

- 1.If you want get the PCM packets, please select a port.
- 2.If you want get the syslog packets, please make sure syslog is enabled.

Start Stop

- ◆ Click "Start" to enable syslog capture
- ◆ Dialing out through the device, start talking a short while then hang up the call.

-
- ◆ Click 'Stop' to disable syslog capture
 - ◆ Save the capture to local computer

The capture package is named 'capture(x).pcap' . x is the serial number of capturing and will be added 1 in next time.

DSP Capture:

DSP capture helps to analyze voice stream inside DSP chipset. The DSP chipset will handle RTP from IP network as well as voice stream from analog phone.

Figure-Capture DSP Packages

Network Capture

Type Network package PCM Syslog DSP

DTU0

Note:

- 1.If you want get the PCM packets, please select a port.
- 2.If you want get the syslog packets, please make sure syslog is enabled.

- ◆ Click Start to enable DSP capture
- ◆ Dialing out through the device, start talking a short while then hang up the call.
- ◆ Click Stop to disable DSP capture
- ◆ Save the capture to local computer

The captured package is named 'capture(x).pcap' . x is the serial number of the capturing and will be added 1 in next time.

Customized Capture:

This menu provides more options to capture specific packages according to actual needs.

Figure-Customized Capturing

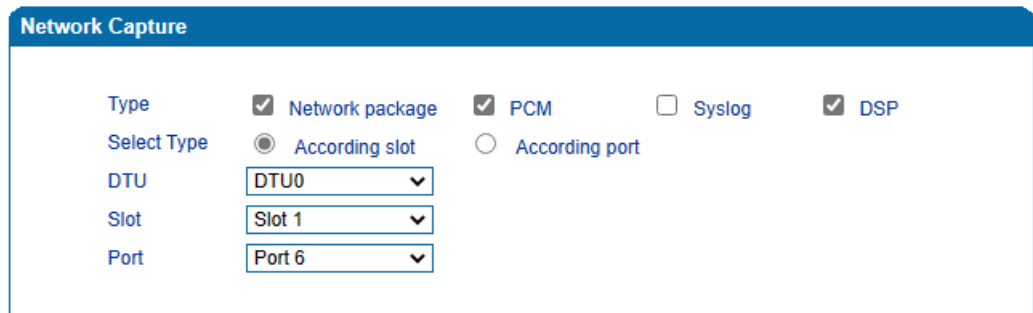

Note:

1.If you want get the PCM packets, please select a port.

2.If you want get the syslog packets, please make sure syslog is enabled.



4.15.8 Factory Reset

Click 'Apply' to restore configurations of the device to the factory default settings.

Figure-Reset Device to Factory Default Setting

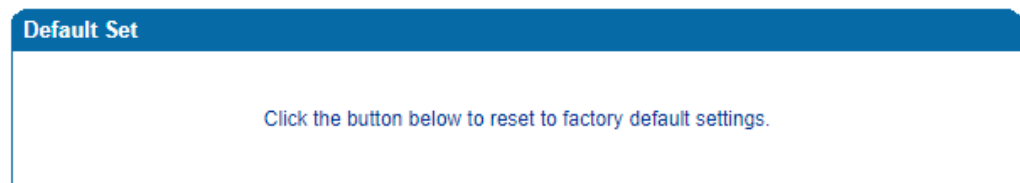

4.15.9 Device Restart

If some parameters are changed, you are required to restart the device for the configurations or changes to take effect.

Figure-Restart Device

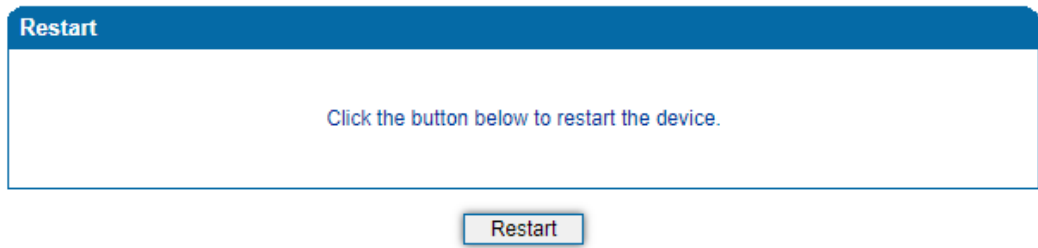

5 Glossary

Abbr.	Full Name
ARP	Address Resolution Protocol
CID	Caller Identity
DNS	Domain Name System
DND	Do NOT Disturb
DTMF	DTMF: Dual Tone Multi Frequency
DHCP	Dynamic Host Configuration Protocol
DMZ	Demilitarized Zone
DDNS	Dynamic Domain Name Server
DSP	Digital Signal Process
NTP	Network Time Protocol
PPPOE	Point-to-point Protocol over Ethernet
PSTN	Public Switched Telephone Network
PCM	Pulse Code Modulation
QoS	Quality of Service
VLAN	Virtual Local Area Network
SIP	Session Initiation Protocol
STUN	Simple Traversal of UDP over NAT
SNMP	Simple Network Management Protocol

RTP	Real Time Protocol
UDP	User Datagram Protocol